

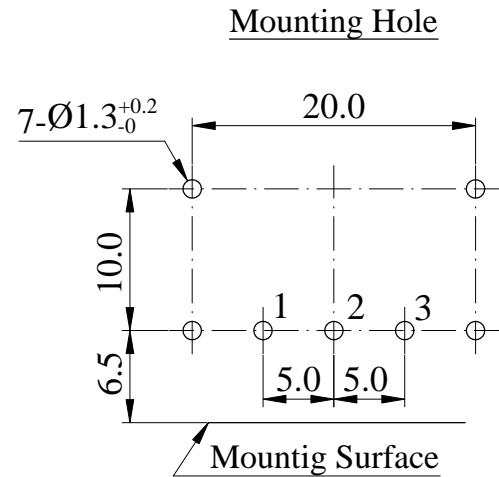

ISO 9001 國際品質認證
ISO 9001 CERTIFICATE

松暉電機工業股份有限公司
SONG HUEI ELECTRIC CO., LTD.
佛山市松暉電機科技有限公司
FOSHAN SONG HUEI ELECTRIC CO., LTD.

一般事項 General	
使用溫度範圍 Operating temperature	-10 °C ~ +70 °C
手工焊接 Manual soldering	260 °C max 3 sec
電氣特性 Electrical Characteristics	
總阻值 (R) Total resistance	5 KΩ ~ 1 MΩ
總阻值容許誤差 Total resistance tolerance	± 20 % (More than 1 MΩ ± 30 %)
阻值線性 Resistance taper	<input type="checkbox"/> A <input type="checkbox"/> B
摺動雜音 Sliding noise	Less than 100 mV
殘留阻值 Residual resistance	Less than 20 Ω
定格電力 Rated power (W)	Linear (B) taper: 0.1 W Other tapers: 0.05 W
額定電壓 Rated voltage (V)	$E = \sqrt{P * R}$ E: Rated voltage 額定電壓 (V) P: Power rating 額定電力 (W) R: Nominal total resistance 公稱全阻抗值 (Ω) 當額定電壓超過最高使用電壓的時候，最高使用電壓即為額定電壓。 When the rated voltage exceeds the maximum operating voltage, the maximum operating voltage shall be the rated voltage.
最高使用電壓 Max operating voltage	AC 100 V
絕緣阻抗 Insulation resistance	More than 100 MΩ at DC 500 V
耐電壓 Withstand voltage	1 minute at AC 500 V
機械特性 Mechanical Characteristics	
全回轉角度 Total rotational angle	300 ° ± 5 °
全回扭力 Rotational torque	20 ~ 200 gf.cm
全回轉止強度 Rotational stopper strength	3 Kgf.cm max
軸推拉強度 Shaft push-pull strength	5 Kgf max
回轉壽命 Rotational life	10,000 cycles

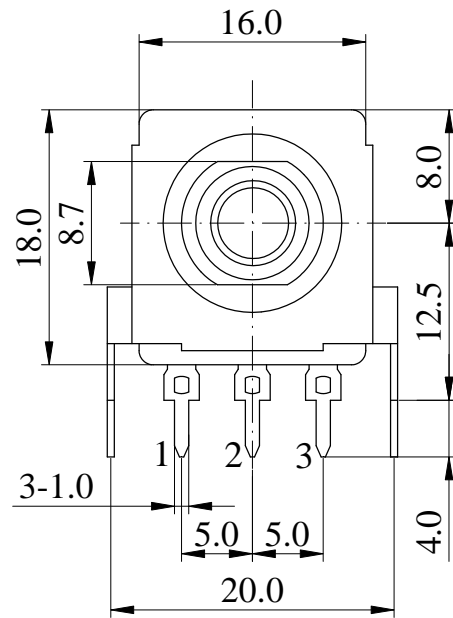
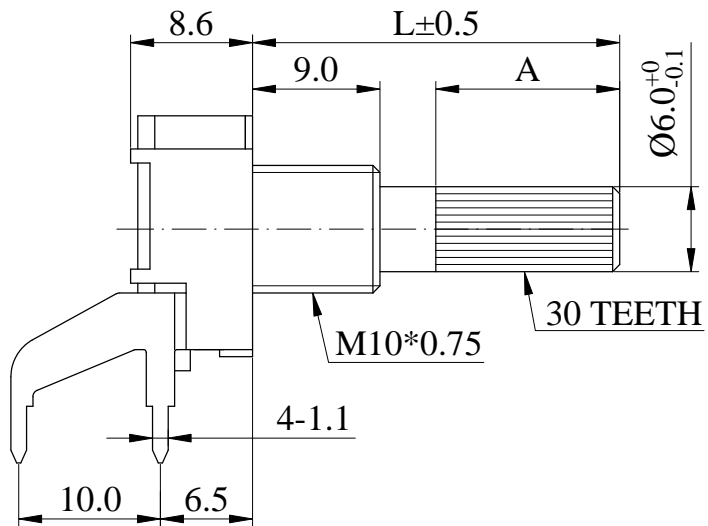

CIRCUIT

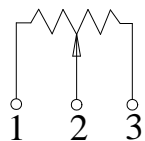

Non notation tolerance

L=	19	24	35	45	< 10	±0.3
A=	8.5	8.5	10	31.5	10 ~ 100	±0.5
choose					> 100	±0.8



SONG HUEI ELECTRIC CO., LTD.
FOSHAN SONG HUEI ELECTRIC CO., LTD.

MODEL: 16KP2(KC)/PH/0083

Approval



Checked



Projected



UNIT	mm	SCALE	2:1
VERSION	1.1	DATE	2013.06.17
DRAWING NO.	16KP-014		

④			
③			
②			
①	图元整理	何鸿根	2018.12.28
ISSUE	SUBJECT	NAME	DATE
RECORD			