

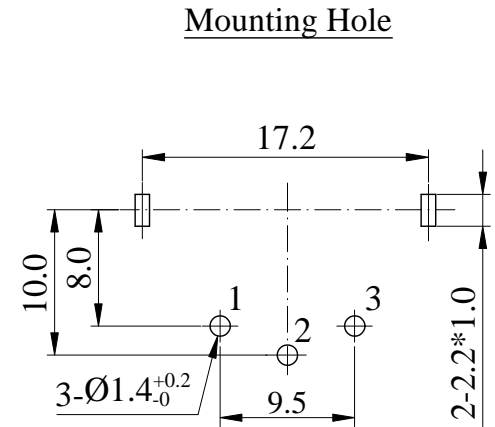

ISO 9001 國際品質認證  
ISO 9001 CERTIFICATE

松暉電機工業股份有限公司  
SONG HUEI ELECTRIC CO., LTD.  
佛山市松暉電機科技有限公司  
FOSHAN SONG HUEI ELECTRIC CO., LTD.

一般事項 General	
使用溫度範圍 Operating temperature	-10 °C ~ +70 °C
手工焊接 Manual soldering	300 °C max 3 sec
電氣特性 Electrical Characteristics	
總阻值 (R) Total resistance	500 Ω ~ 500 KΩ
總阻值容許誤差 Total resistance tolerance	± 20 %
阻值線性 Resistance taper	<input type="checkbox"/> A <input type="checkbox"/> B <input type="checkbox"/> C <input type="checkbox"/> D
摺動雜音 Sliding noise	Less than 100 mV
殘留阻值 Residual resistance	Less than 10 Ω
定格電力 Rated power (W)	Linear (B) taper: 0.1 W Other tapers: 0.05 W
額定電壓 Rated voltage (V)	$E = \sqrt{P * R}$ E: Rated voltage 額定電壓 (V) P: Power rating 額定電力 (W) R: Nominal total resistance 公稱全阻抗值 (Ω) 當額定電壓超過最高使用電壓的時候，最高使用電壓即為額定電壓。 When the rated voltage exceeds the maximum operating voltage, the maximum operating voltage shall be the rated voltage.
最高使用電壓 Max operating voltage	Linear (B) taper: AC 200 V Other tapers: AC 150 V
絕緣阻抗 Insulation resistance	More than 50 MΩ at DC 500 V
耐電壓 Withstand voltage	1 minute at AC 500 V
機械特性 Mechanical Characteristics	
全回轉角度 Total rotational angle	260 ° ± 10 °
全回轉扭力 Rotational torque	20 ~ 150 gf.cm
全回轉止強度 Rotational stopper strength	2 Kgf.cm max
軸推拉強度 Shaft push-pull strength	1 Kgf max
回轉壽命 Rotational life	10,000 cycles

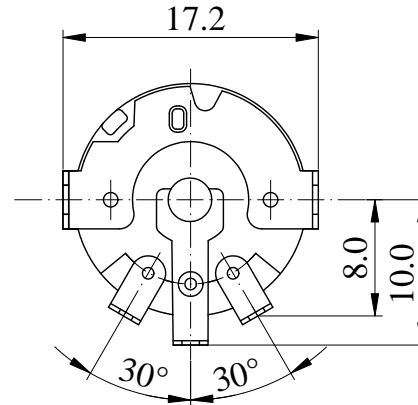
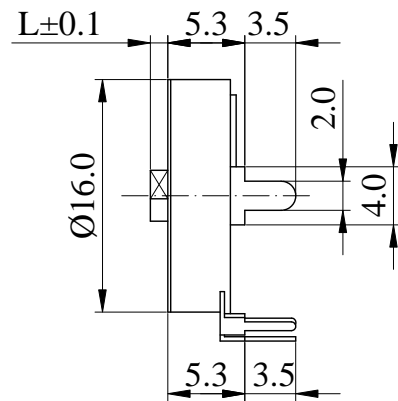
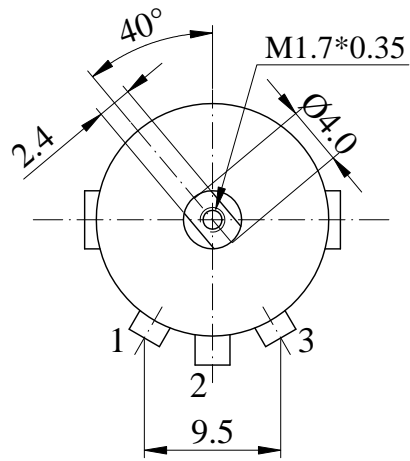

SHAFT SHOWN IN FULL C.C.W POSITION

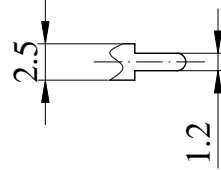

CIRCUIT

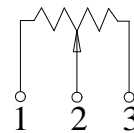

Non notation tolerance

					< 10	±0.3
					10 ~ 100	±0.5
					> 100	±0.8
	L=	1.2	1.5			
	choose					



SONG HUEI ELECTRIC CO., LTD.  
FOSHAN SONG HUEI ELECTRIC CO., LTD.

MODEL: 16N4/0426

Approval



Checked



Projected



UNIT

mm

SCALE

2.5:1

VERSION

1.1

DATE

2013.01.30

DRAWING NO.

R16-019

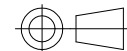

④

③

②

①

ISSUE

整理图元

SUBJECT

何鴻根

NAME

2018.12.20

DATE

RECORD

# Shaft Types 軸型:

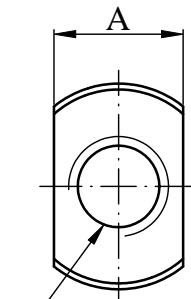
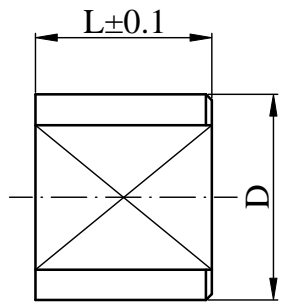

M1.7\*0.35 DEEP 3.5

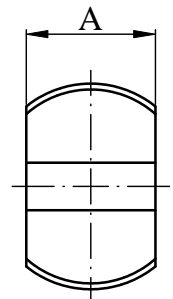
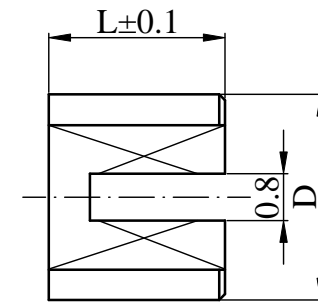
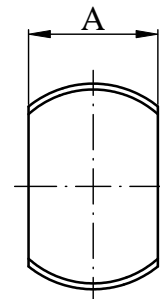
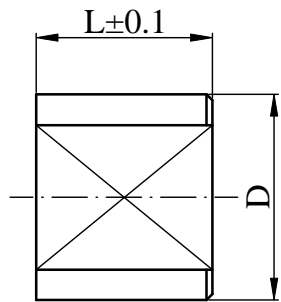

Tap Type

L	1.0-5.0
A	2.2±0/0.1
D	Ø3.5

NO Tap Type

L	1.0-5.0
A	2.2±0/0.1
D	Ø3.5

Slotted Type

L	1.0-5.0
A	2.2±0/0.1
D	Ø3.5