

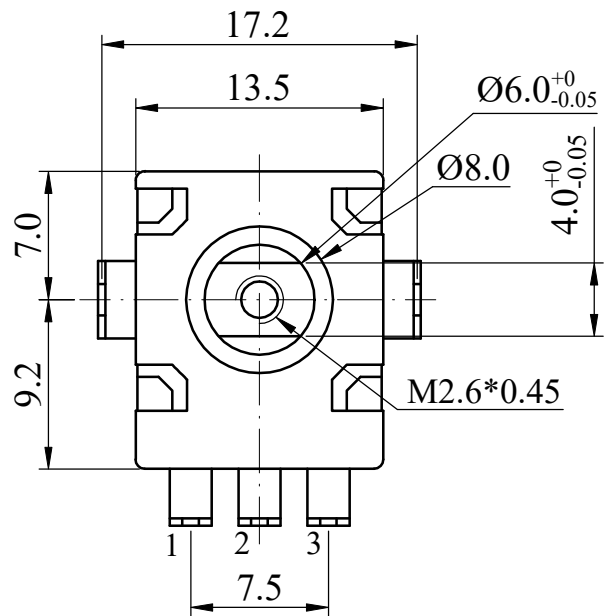

ISO 9001 國際品質認證
ISO 9001 CERTIFICATE

松暉電機工業股份有限公司
SONG HUEI ELECTRIC CO., LTD.
佛山市松暉電機科技有限公司
FOSHAN SONG HUEI ELECTRIC CO., LTD.

一般事項 General	
使用溫度範圍 Operating temperature	-20 °C ~ +70 °C
儲存溫度 Storage temperature range	-40 °C ~ +80 °C
手工焊接 Manual soldering	260 °C max 3 sec
電氣特性 Electrical Characteristics	
總阻值 (R) Total resistance	1KΩ ~ 100 KΩ
總阻值容許誤差 Total resistance tolerance	±10 %
阻值線性 Resistance taper	A <input type="checkbox"/> B <input type="checkbox"/> C <input type="checkbox"/> D <input type="checkbox"/>
摺動雜音 Sliding noise	Less than 100 mV
殘留阻值 Residual resistance	≤3% Ω
定格電力 Rated power (W)	Linear (B) taper: 0.05 W Other tapers: 0.03 W
額定電壓 Rated voltage (V)	$E = \sqrt{P * R}$ E: Rated voltage 額定電壓 (V) P: Power rating 額定電力 (W) R: Nominal total resistance 公稱全阻抗值 (Ω) 當額定電壓超過最高使用電壓的時候，最高使用電壓即為額定電壓。 When the rated voltage exceeds the maximum operating voltage, the maximum operating voltage shall be the rated voltage.
最高使用電壓 Max operating voltage	AC 50V / DC 20V
絕緣阻抗 Insulation resistance	More than 100 MΩ at DC 250 V
耐電壓 Withstand voltage	1 minute at AC 300 V
機械特性 Mechanical Characteristics	
全回轉角度 Total rotational angle	<input type="checkbox"/> 170 ° ± 5 ° <input type="checkbox"/> 180 ° ± 5 ° <input type="checkbox"/> 270 ° ± 5 °
全回轉扭力 Rotational torque	20 ~ 200 gf.cm
全回轉止強度 Rotational stopper strength	3 Kgf.cm max
軸推拉強度 Shaft push-pull strength	3 Kgf max
回轉壽命 Rotational life	30,000 cycles



SHAFT SHOWN IN FULL C.C.W POSITION

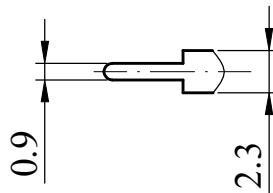
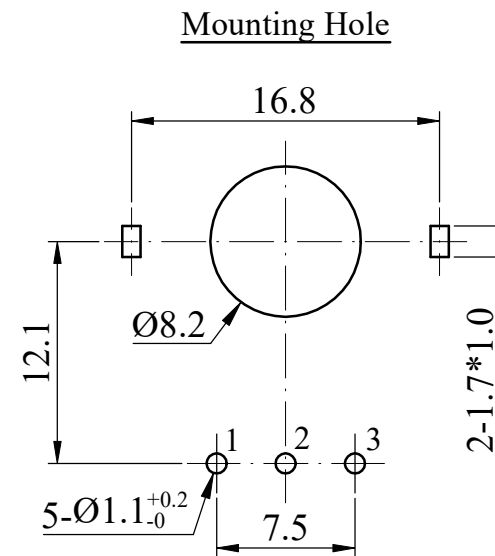
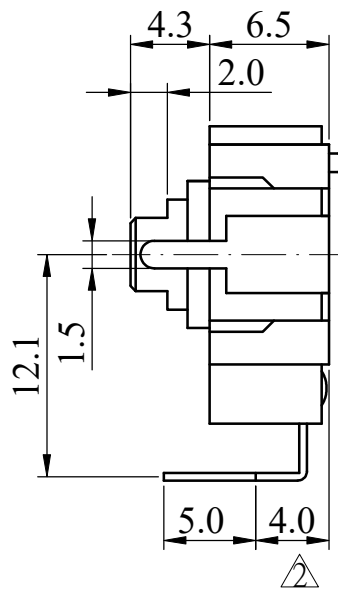

CIRCUIT

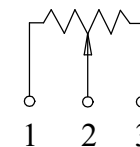

Non notation tolerance	
< 10	±0.3
10 ~ 100	±0.5
> 100	±0.8



SONG HUEI ELECTRIC CO., LTD.
FOSHAN SONG HUEI ELECTRIC CO., LTD.

MODEL: 18PN1/0426

Approval



Checked



Drawn



UNIT	mm	SCALE	2.5:1
VERSION	1.2	DATE	2015.12.16
DRAWING NO.	18PN-004		

	原4.6改为4	何鸿根	2022.08.12
	图元整理	何鸿根	2018.12.29
ISSUE	SUBJECT	NAME	DATE

RECORD