



ISO 9001 國際品質認證
ISO 9001 CERTIFICATE

松暉電機工業股份有限公司
SONG HUEI ELECTRIC CO., LTD.
佛山市松暉電機科技有限公司
FOSHAN SONG HUEI ELECTRIC CO., LTD.

一般事項 General	
使用溫度範圍 Operating temperature	-30 °C ~ 80 °C
儲存溫度 Storage temperature	-40 °C ~ 85 °C
電氣特性 Electrical Characteristics	
額定功率 Power rating	DC 5 V 0.5 mA
絕緣阻抗 Insulation resistance	$\geq 100 \text{ M}\Omega$ at DC 250 V
耐電壓 Withstand voltage	For 1 minute or more (at AC 300 V)
滑動雜訊 Sliding noise	<p>$t_1, t_3 \leq 3 \text{ mS}$, $t_2 \leq 2 \text{ mS}$ (Test conditions 測試條件: $360^\circ / \text{S}$) Using the C / R filter circuit is recommended 建議使用 C / R 濾波電路</p>
分解能力 Resolution	15 pulses / 360 ° for each phase 每相 15 脈衝 / 360 °
相位差 Phase difference	$\Delta T = 0.25 \pm 0.17 T$
輸出信號和旋轉方向 Output signal and rotational direction	<p>順時針方向 A Signal</p> <p>C.W direction B Signal</p>
機械特性 Mechanical Characteristics	
全回轉角度 Total rotational angle	360 °
全回力矩 Rotational torque	50 ~ 250 gf.cm
定位點數及位置 Number and position detent	30 detents (Step angle: $12^\circ \pm 2^\circ$)
軸的回轉方向 Shaft in play/rotational wobble	5° max
回轉壽命 Rotational life	30,000 cycles at a speed of 600 cycles / per hour 每小時 600 圈的速度測試
焊錫耐熱性 Resistance to soldering heat	<p>手焊: 300 °C 以下, 3 秒以內. 自動或半自動機台焊錫條件: 預熱: 基板表面溫度 100 °C 以下, 時間 1 分以內, 過錫爐: $230 \pm 5^\circ \text{C}$ 3 秒 ± 0.5 秒 Manual soldering: less than 300 °C and within 3 seconds. For automated or semi-automated soldering equipments: Preheating: surface temperature of board: less than 100 °C and within 1 min. Auto soldering: $230 \pm 5^\circ \text{C}$ 3S ± 0.5 S .</p>
耐濕性 Rotstional heat	<p>溫度 $40 \pm 2^\circ \text{C}$, 濕度 90 ~ 95% 的恒溫恒濕槽中放置 96 ± 4 小時後, 在常溫、常濕中放置 1.5 小時後測試。 The encoder shall be stored at temperature of $40 \pm 2^\circ \text{C}$ with relative humidity of 90% to 95% for $96 \pm 4\text{H}$ satisfied in a thermostatic chamber. And the encoder shall be subjected to standard atmospheric conditions for 1.5H, After which measurements shall be made.</p>



ISO 9001 國際品質認證
ISO 9001 CERTIFICATE

松 暉 電 機 工 業 股 份 有 限 公 司
SONG HUEI ELECTRIC CO., LTD.
佛 山 市 松 暉 電 機 科 技 有 限 公 司
FOSHAN SONG HUEI ELECTRIC CO., LTD.

耐热性 Damp heat	温度 $85 \pm 3^{\circ}\text{C}$ 的恒温箱中放置 96 ± 4 小时后,在常温、常湿中放置1.5小时后测试. The encoder shall be stored at temperature of $85 \pm 3^{\circ}\text{C}$ for $96 \pm 4\text{H}$ satisfied.in a thermostatic chamber.And the encoder shall be subjected to standard atmospheric conditions for 1.5H,After which measurements shall be made.
低温特性 Cold	温度 $-40 \pm 3^{\circ}\text{C}$ 的恒温箱中放置 96 ± 4 小时 后,在常温、常湿中放置1.5小时后测试. The encoder shall be stored at temperature of $-40 \pm 3^{\circ}\text{C}$ for $96 \pm 4\text{H}$ satisfied.in a thermostatic chamber.And the encoder shall be subjected to standard atmospheric conditions for 1.5H,After which measurements shall be made.

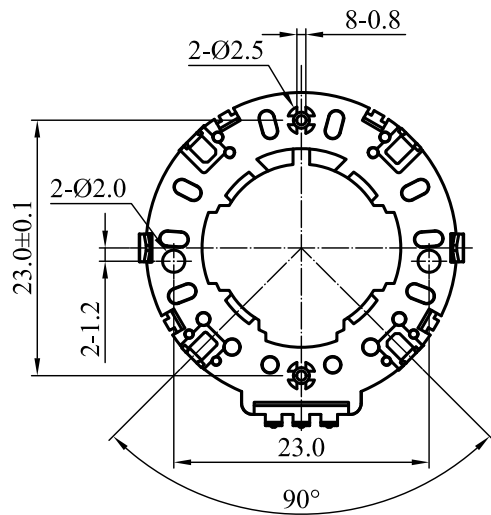

Mounting Hole

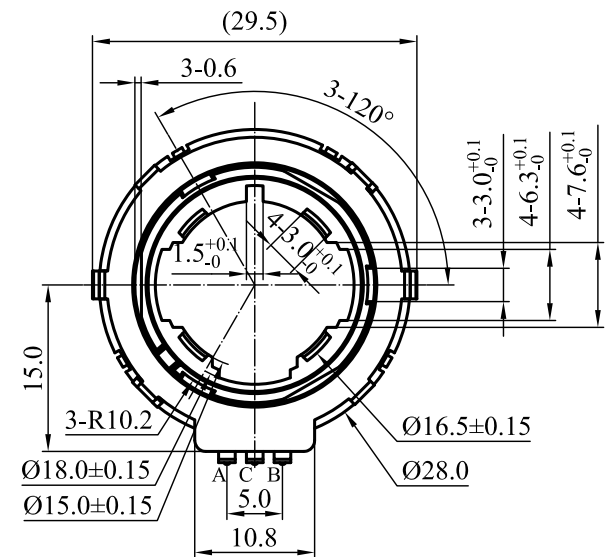
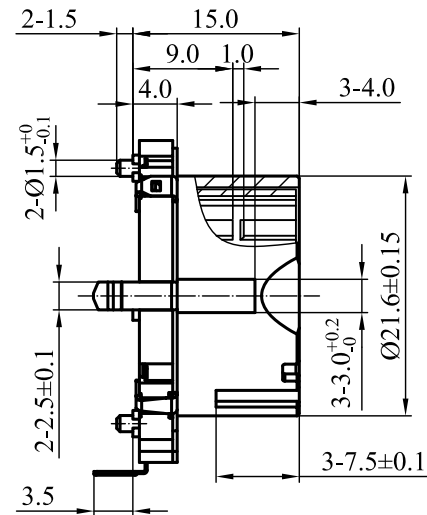
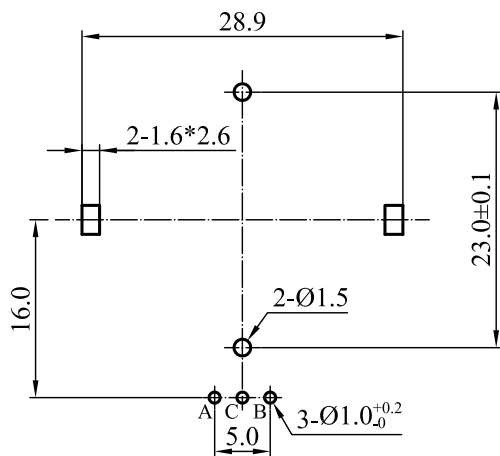

CIRCUIT

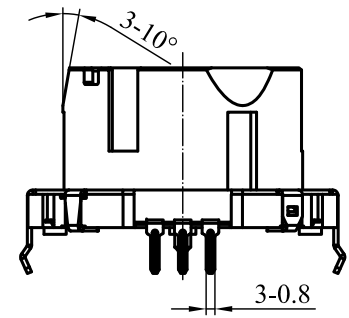
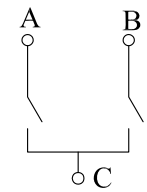

Non notation tolerance	
< 10	±0.3
10 ~ 100	±0.5
> 100	±0.8



SONG HUEI ELECTRIC CO., LTD.
FOSHAN SONG HUEI ELECTRIC CO., LTD.

MODEL: EC028-002/0496

Approval

R&D
2019-11-13
藍濬毅

Checked

廠長
2019-11-13
鄧記穩

Projected

R&D
2019-11-13
何鴻根

UNIT	mm	SCALE	1.5:1
VERSION	1.1	DATE	2015.05.21
DRAWING NO.	ED-060		

△4			
△3			
△2			
△1	图元整理	何鸿根	2019. 11. 13
ISSUE	SUBJECT	NAME	DATE

RECORD