

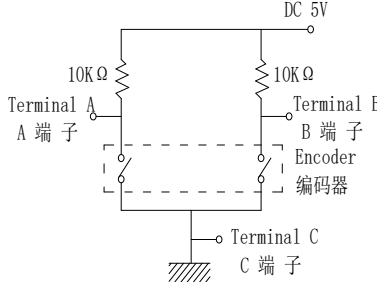

ISO 9001 國際品質認證
ISO 9001 CERTIFICATE

松暉電機工業股份有限公司
SONG HUEI ELECTRIC CO., LTD.
佛山市松暉電機科技有限公司
FOSHAN SONG HUEI ELECTRIC CO., LTD.

一般事項 General	
使用溫度範圍 Operating temperature	-30 °C ~ 80 °C
儲存溫度 Storage temperature	-40 °C ~ 85 °C
電氣特性 Electrical Characteristics	
額定功率 Power rating	DC 5 V 0.5 mA
絕緣阻抗 Insulation resistance	≥ 100 MΩ at DC 250 V
耐電壓 Withstand voltage	For 1 minute or more (at AC 300 V)
滑動雜訊 Sliding noise	<p>t1, t3 ≤ 3 mS, t2 ≤ 2 mS (Test conditions 測試條件: 360 ° / S) Using the C / R filter circuit is recommended 建議使用 C / R 濾波電路</p>  
分解能力 Resolution	15 pulses / 360 ° for each phase 每相 15脈衝 / 360 °
相位差 Phase difference	Δ T = 0.25 ± 0.17 T
輸出信號和旋轉方向 Output signal and rotational direction	<p>順時針方向 A Signal</p> <p>C.W direction B Signal</p> 
機械特性 Mechanical Characteristics	
全回轉角度 Total rotational angle	360 °
全回力矩 Rotational torque	100 ~ 300 gf.cm
定位點數及位置 Number and position detent	30 detents (Step angle: 12 ° ± 2 °)
軸的回轉方向 Shaft in play/rotational wobble	5° max
回轉壽命 Rotational life	30,000 cycles at a speed of 600 cycles / per hour 每小時 600 圈的速度測試
焊錫耐熱性 Resistance to soldering heat	<p>手焊: 300 °C 以下, 3 秒以內. 自動或半自動機台焊錫條件: 預熱: 基板表面溫度 100 °C 以下, 時間 1 分以內, 過錫爐: 230 °C ± 5 °C 3 秒 ± 0.5 秒 Manual soldering: less than 300 °C and within 3 seconds. For automated or semi-automated soldering equipments: Preheating: surface temperature of board: less than 100 °C and within 1 min. Auto soldering: 230 °C ± 5 °C 3S ± 0.5S .</p>
耐濕性 Rotstional heat	<p>溫度 40 °C ± 2 °C, 濕度 90% ~ 95% 的恒溫恒濕槽中放置 96 ± 4 小時後, 在常溫、常濕中放置 1.5 小時後測試. The encoder shall be stored at temperature of 40 °C ± 2 °C with relative humidity of 90% to 95% for 96 ± 4H satisfied.in a thermostatic chamber. And the encoder shall be subjected to standard atmospheric conditions for 1.5H, After which measurements shall be made.</p>
耐熱性 Damp heat	<p>溫度 85 °C ± 3 °C 的恒溫箱中放置 96 ± 4 小時後, 在常溫、常濕中放置 1.5 小時後測試. The encoder shall be stored at temperature of 85 °C ± 3 °C for 96 ± 4H satisfied.in a thermostatic chamber. And the encoder shall be subjected to standard atmospheric conditions for 1.5H, After which measurements shall be made.</p>

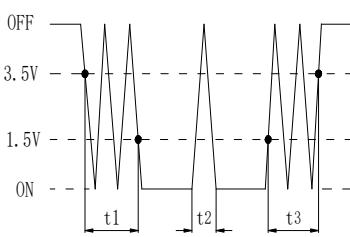
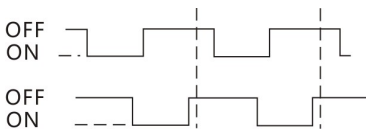

ISO 9001 國際品質認證
ISO 9001 CERTIFICATE

松 暉 電 機 工 業 股 份 有 限 公 司
SONG HUEI ELECTRIC CO., LTD.
佛 山 市 松 暉 電 機 科 技 有 限 公 司
FOSHAN SONG HUEI ELECTRIC CO., LTD.

低温特性
Cold

温度-40°C ± 3°C的恒温箱中放置96 ± 4小时 后,在常温、常湿中放置1.5小时后测试.
The encoder shall be stored at temperature of -40°C ± 3°C for 96 ± 4H satisfied.in a thermostatic chamber.And the encoder shall be subjected to standard atmospheric conditions for 1.5H,After which measurements shall be made.

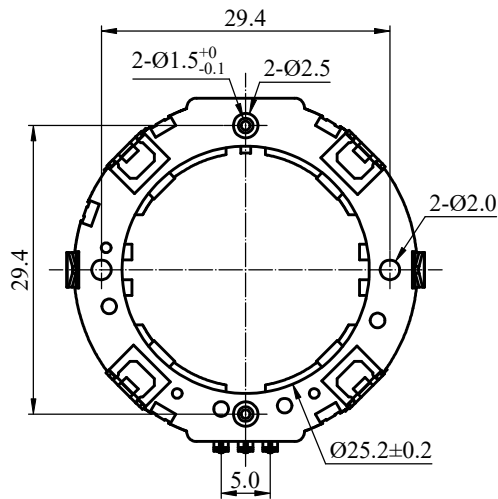

Mounting Hole

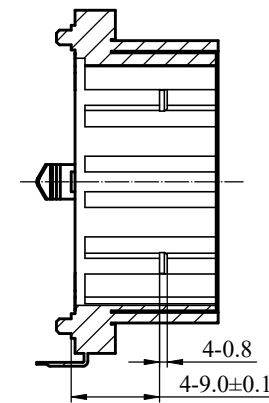
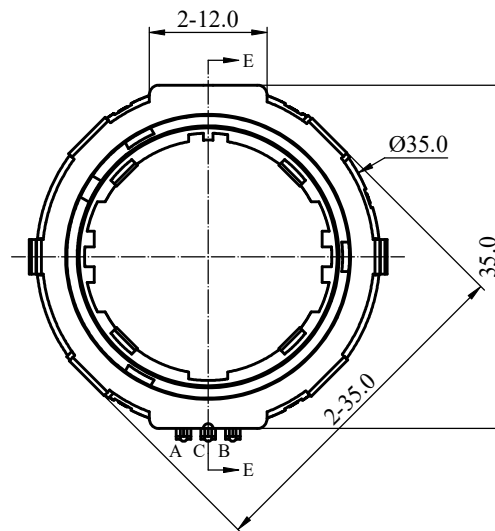
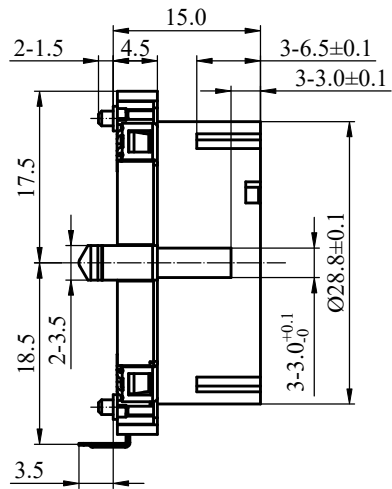

SECTION E-E

CIRCUIT

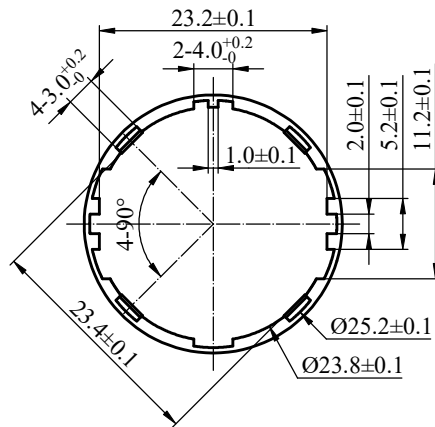
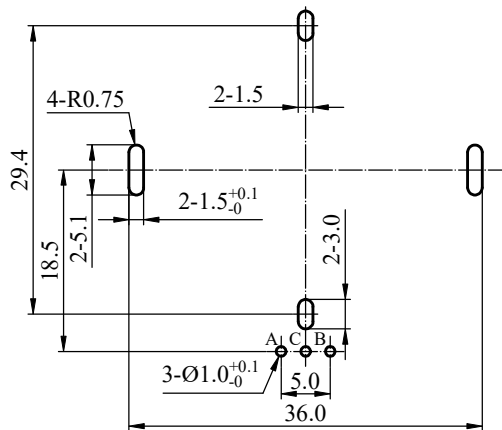
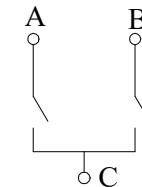

CENTER HOLE DETAIL

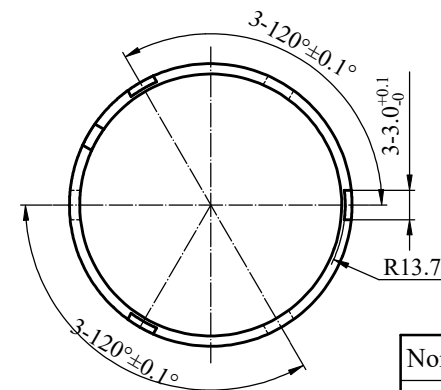
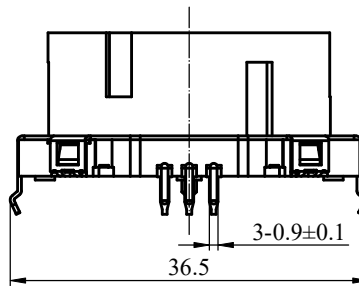

SHAFT DETAIL

Non notation tolerance	
< 10	±0.3
10 ~ 100	±0.5
> 100	±0.8



SONG HUEI ELECTRIC CO., LTD.
FOSHAN SONG HUEI ELECTRIC CO., LTD.

MODEL: EC035-002/0496

Approval



Checked



Projected



UNIT	mm	SCALE	1.5:1
VERSION	1.0	DATE	2019.11.13
DRAWING NO.	ED-107		
RECORD			

△			
△			
△			
△			
ISSUE	SUBJECT	NAME	DATE
RECORD			