



ISO 9001 國際品質認證  
ISO 9001 CERTIFICATE

松暉電機工業股份有限公司  
SONG HUEI ELECTRIC CO., LTD.  
佛山市松暉電機科技有限公司  
FOSHAN SONG HUEI ELECTRIC CO., LTD.

一般事項 General															
使用溫度範圍 Operating temperature	-30 °C ~ 80 °C														
儲存溫度 Storage temperature	-40 °C ~ 85 °C														
電氣特性 Electrical Characteristics															
額定功率 Power rating	DC 5 V 0.5 mA														
絕緣阻抗 Insulation resistance	≥ 100 MΩ at DC 250 V														
耐電壓 Withstand voltage	For 1 minute or more ( at AC 300 V )														
滑動雜訊 Sliding noise	<p>t1, t3 ≤ 3 mS, t2 ≤ 2 mS ( Test conditions 測試條件: 360 ° / S ) Using the C / R filter circuit is recommended 建議使用 C / R 濾波電路</p>														
分解能力 Resolution	15 pulses / 360 ° for each phase 每相 15脈衝 / 360 °														
相位差 Phase difference	<p>ΔT ≥ 4mS ( shaft is rotated at 60r/min 軸以360 ° / S 的速度转动測定 )</p>														
輸出信號和旋轉方向 Output signal and rotational direction	<table border="1"> <tbody> <tr> <td rowspan="3">順時針方向 C. W</td> <td>A (A-D端子間) A (Terminal A-D)</td> <td>OFF ———— ON - - - - -</td> </tr> <tr> <td>B (B-D端子間) B (Terminal B-D)</td> <td>OFF ———— ON - - - - -</td> </tr> <tr> <td>C (C-D端子間) C (Terminal C-D)</td> <td>OFF ———— ON - - - - -</td> </tr> <tr> <td rowspan="3">逆時針方向 C. C. W</td> <td>A (A-D端子間) A (Terminal A-D)</td> <td>OFF ———— ON - - - - -</td> </tr> <tr> <td>B (B-D端子間) B (Terminal B-D)</td> <td>OFF ———— ON - - - - -</td> </tr> <tr> <td>C (C-D端子間) C (Terminal C-D)</td> <td>OFF ———— ON - - - - -</td> </tr> </tbody> </table>	順時針方向 C. W	A (A-D端子間) A (Terminal A-D)	OFF ———— ON - - - - -	B (B-D端子間) B (Terminal B-D)	OFF ———— ON - - - - -	C (C-D端子間) C (Terminal C-D)	OFF ———— ON - - - - -	逆時針方向 C. C. W	A (A-D端子間) A (Terminal A-D)	OFF ———— ON - - - - -	B (B-D端子間) B (Terminal B-D)	OFF ———— ON - - - - -	C (C-D端子間) C (Terminal C-D)	OFF ———— ON - - - - -
順時針方向 C. W	A (A-D端子間) A (Terminal A-D)		OFF ———— ON - - - - -												
	B (B-D端子間) B (Terminal B-D)		OFF ———— ON - - - - -												
	C (C-D端子間) C (Terminal C-D)	OFF ———— ON - - - - -													
逆時針方向 C. C. W	A (A-D端子間) A (Terminal A-D)	OFF ———— ON - - - - -													
	B (B-D端子間) B (Terminal B-D)	OFF ———— ON - - - - -													
	C (C-D端子間) C (Terminal C-D)	OFF ———— ON - - - - -													
機械特性 Mechanical Characteristics															
全回轉角度 Total rotational angle	360 °														
全回力矩 Rotational torque	100 ~ 400 gf.cm														
定位點數及位置 Number and position detent	30 detents ( Step angle: 12 ° ± 3 ° )														
回轉壽命 Rotational life	30,000 cycles at a speed of 600 cycles / per hour 每小時 600 圈的速度測試														



ISO 9001 國際品質認證  
ISO 9001 CERTIFICATE

松暉電機工業股份有限公司  
SONG HUEI ELECTRIC CO., LTD.  
佛山市松暉電機科技有限公司  
FOSHAN SONG HUEI ELECTRIC CO., LTD.

焊錫耐熱性 Soldering heat resistance	手焊: 300 °C 以下, 3 秒以內。 自動或半自動機台焊錫條件: 預熱基板表面溫度 100 °C 以下, 時間 1 分以內, 焊接溫度 $230 \pm 5$ °C 以下, 時間 3 秒以內。 Manual soldering: less than 300 °C and within 3 seconds. For automated or semi-automated soldering equipments: Preheating surface temperature of board: less than 100 °C and within 1 min. Solder temperature: $230 \pm 5$ °C or less. Immersion time: within 3S.
濕度測試 Humidity test	溫度 $40 \pm 2$ °C, 濕度 90 ~ 95% 的恒溫恒濕槽中放置 $96 \pm 4$ 小時後, 在常溫、常濕中放置 1.5 小時後測試。 The encoder shall be stored at temperature of $40 \pm 2$ °C with relative humidity of 90% to 95% for $96 \pm 4$ H satisfied in a thermostatic chamber. And the encoder shall be subjected to standard atmospheric conditions for 1.5H. After which measurements shall be made.
高溫測試 Heat test	溫度 $85 \pm 3$ °C 的恒溫箱中放置 $96 \pm 4$ 小時後, 在常溫、常濕中放置 1.5 小時後測試。 The encoder shall be stored at temperature of $85 \pm 3$ °C for $96 \pm 4$ H satisfied in a thermostatic chamber. And the encoder shall be subjected to standard atmospheric conditions for 1.5H. After which measurements shall be made.
低溫特性 Cold test	溫度 $-40 \pm 3$ °C 的恒溫箱中放置 $96 \pm 4$ 小時後, 在常溫、常濕中放置 1.5 小時後測試。 The encoder shall be stored at temperature of $-40 \pm 3$ °C for $96 \pm 4$ H satisfied in a thermostatic chamber. And the encoder shall be subjected to standard atmospheric conditions for 1.5H. After which measurements shall be made.

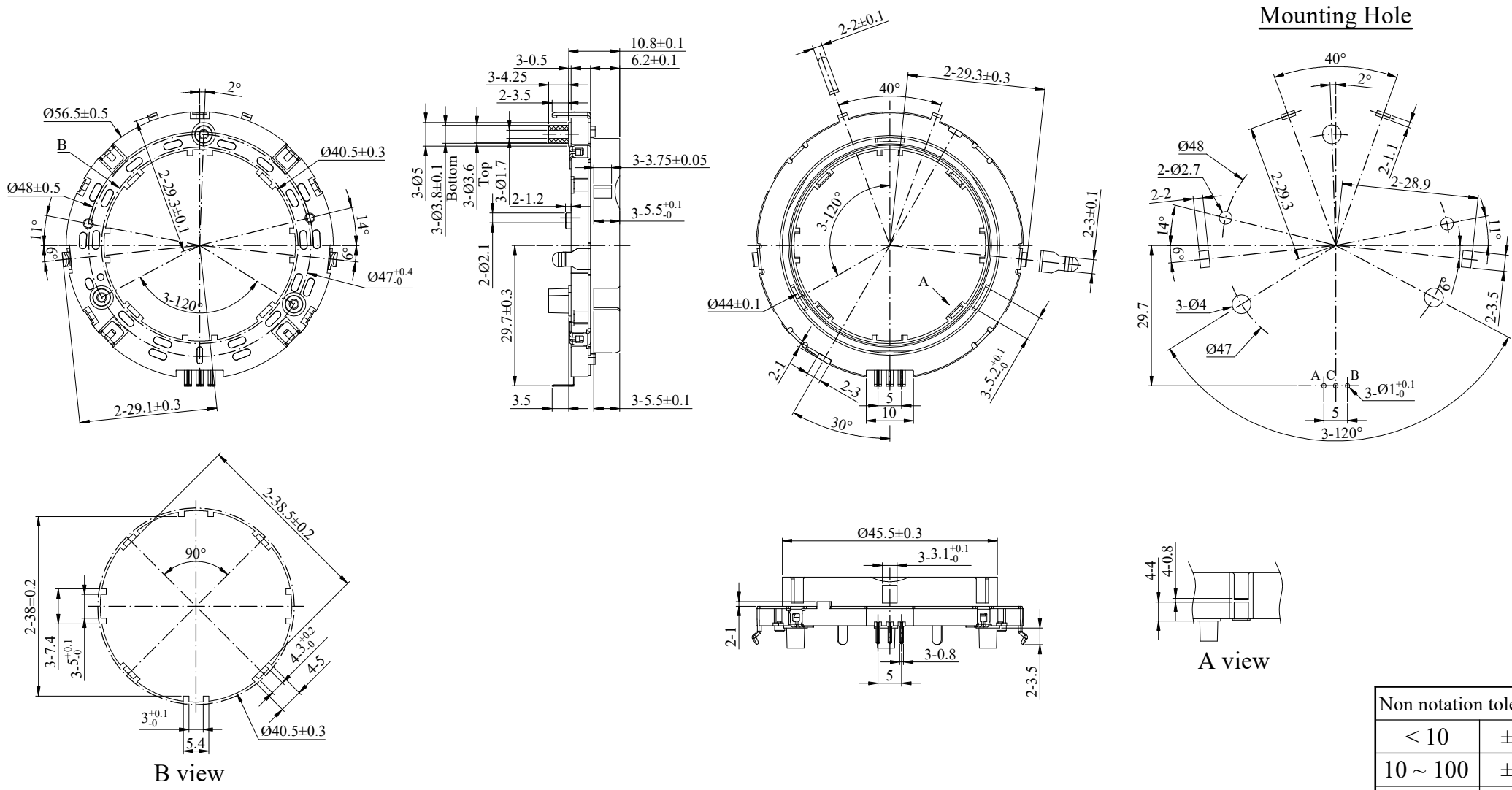

Non notation tolerance	
< 10	±0.3
10 ~ 100	±0.5
> 100	±0.8

**S**® SONG HUEI ELECTRIC CO., LTD.  
FOSHAN SONG HUEI ELECTRIC CO., LTD.

MODEL: EC056-001/0496

△			
△			
△			
△			
ISSUE	SUBJECT	NAME	DATE
RECORD			

Approval

**R&D**  
2021-05-07  
藍濬毅

Checked

廠長  
2021-05-07  
鄧記穩

Projected

**R&D**  
2021-05-07  
何鴻根

UNIT	mm	SCALE	1:1.2
VERSION	1.0	DATE	2021.05.07
DRAWING NO.	ED-117		