



ISO 9001 國際品質認證
ISO 9001 CERTIFICATE

松暉電機工業股份有限公司
SONG HUEI ELECTRIC CO., LTD.
佛山市松暉電機科技有限公司
FOSHAN SONG HUEI ELECTRIC CO., LTD.

一般事項 General	
使用溫度範圍 Operating temperature	-10 °C ~ 70 °C
儲存溫度 Storage temperature	-40 °C ~ 85 °C
電氣特性 Electrical Characteristics	
額定功率 Power rating	DC 5 V 0.5 mA
絕緣阻抗 Insulation resistance	100 MΩ at DC 300 V
耐電壓 Withstand voltage	For 1 minute or more (at AC 300 V)
滑動雜訊 Sliding noise	<p>$t_1, t_3 \leq 3 \text{ mS}$, $t_2 \leq 2 \text{ mS}$ (Test conditions 測試條件: $360^\circ / \text{S}$) Using the C / R filter circuit is recommended 建議使用 C / R 濾波電路</p>
分解能力 Resolution	<input type="checkbox"/> 12 <input type="checkbox"/> 24 個相位脈衝 / 360° <input type="checkbox"/> 12 <input type="checkbox"/> 24 pulses / 360° for each phase.
相位差 Phase difference	$\Delta T = 0.25 \pm 0.17 \text{ T}$
輸出信號和旋轉方向 Output signal and rotational direction	<p>順時針方向 A Signal OFF ON</p> <p>C.W direction B Signal OFF ON</p>
機械特性 Mechanical Characteristics	
全回轉角度 Total rotational angle	360°
全回力矩 Rotational torque	20 ~ 200 gf.cm (Shaft may be hard rotatable at -10 °C ~ +5 °C 但在 -10 °C ~ +5 °C 軸勉強可轉動)
軸推拉強度 Shaft push-pull strength	<input type="checkbox"/> With switch 5 Kgf <input type="checkbox"/> without switch 8 Kgf <input type="checkbox"/> 帶開關為 5 Kgf <input type="checkbox"/> 不帶開關為 8 Kgf
定位點數及位置 Number and position detent	<input type="checkbox"/> 12 detents (Step angle: $30^\circ \pm 3^\circ$) <input type="checkbox"/> 24 detents (Step angle: $15^\circ \pm 3^\circ$) <input type="checkbox"/> 0 detents (Step angle: 360°)
軸向間隙 Shaft play in axial direction	0.4 mm max
軸擺動 Shaft wobble	<p>0.7 * L / 30 mm p-p 以下 (L: 指安裝平面到軸的柄端的距離) 0.7 * L / 30 mm p-p Max L: Distance between mounting surface and the top of the shaft.</p>
軸的回轉方向擺動 Shaft play in rotational wobble	<p>5° 以下 5° Max</p>
回轉壽命 Rotational life	30,000 cycles at a speed of 600 cycles / per hour 每小時 600 圈的速度測試



ISO 9001 國際品質認證
ISO 9001 CERTIFICATE

松 暉 電 機 工 業 股 份 有 限 公 司
SONG HUEI ELECTRIC CO., LTD.
佛 山 市 松 暉 電 機 科 技 有 限 公 司
FOSHAN SONG HUEI ELECTRIC CO., LTD.

焊錫耐熱性 Resistance to soldering heat	手焊: 300 °C 以下, 3 秒以內. 自動或半自動機台焊錫條件: 預熱: 基板表面溫度 100 °C 以下, 時間 1 分以內, 過錫爐: 260 ± 5 °C 3 ~ 5 秒 Manual soldering: less than 300 °C and within 3 seconds. For automated or semi-automated soldering equipments: Preheating: surface temperature of board: less than 100 °C and within 1 min. Auto soldering: 260 ± 5 °C for 3 ~ 5 seconds.
推動開關規格 Push-on Switch Specific Ations	
開關電路 Switch circuit	Single pole and single throw (push on) 單極單投 (推動)
開關工作行程 Switch travel (mm)	0.5 ^{+0.4} _{-0.3} mm
開關作動力 Switch operating force	500 ⁺²⁰⁰ ₋₂₀₀ gf.cm
開關額定功率 Switch rating power	DC 5 V 10 mA
開關接觸阻抗 Switch contact resistance	第一個週期: 100 mΩ, 在有效的壽命範圍結束後 200 mΩ First period 100 mΩ ; 200 mΩ after the end of useful life is reached
開關按壓壽命 Switch push life	20,000 cycles (500 cycles / H, shaft push load 1 kgf max ; 按壓力 1 kg 以下, 500 次 / H)
Note 注明: 當產品無帶開關結構時, 以上推動開關規格整項取消 Note: When product without switch structure, the above switch specifications are cancelled.	

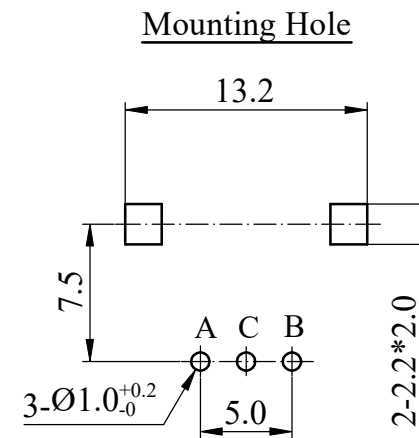
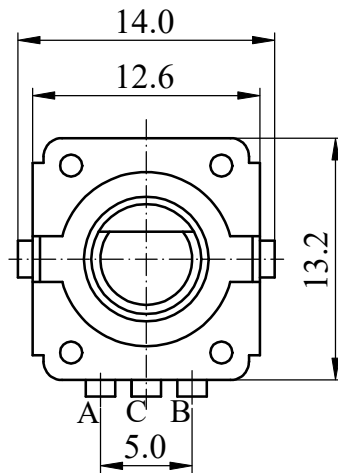
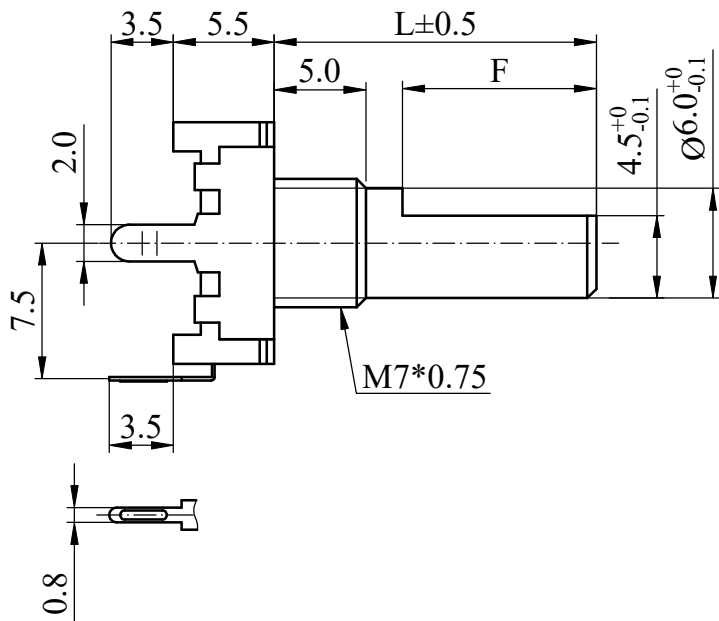

CIRCUIT

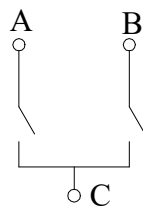

							Non notation tolerance	
L=	15	20	25	30			< 10	±0.3
F=	7	12	12	12			10 ~ 100	±0.5
choose							> 100	±0.8

S® SONG HUEI ELECTRIC CO., LTD.
FOSHAN SONG HUEI ELECTRIC CO., LTD.

MODEL: ED1215(F)/LAL/0496

△			
△			
△			
△			
ISSUE	SUBJECT	NAME	DATE

Approval

Checked

Projected

UNIT	mm	SCALE	2:1
VERSION	1.0	DATE	2019.10.08
DRAWING NO.	ED-100		

RECORD