

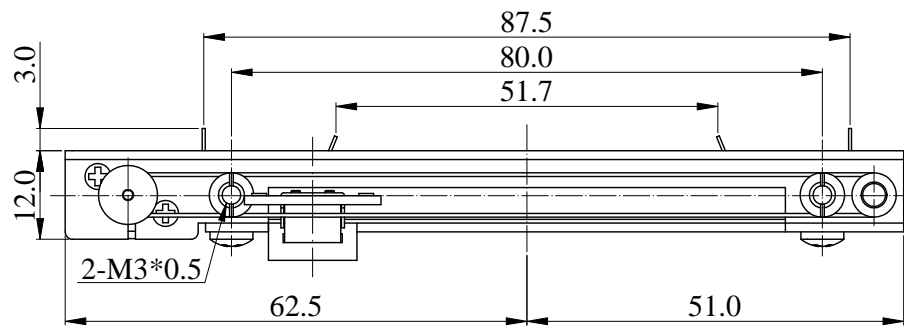

ISO 9001 國際品質認證
ISO 9001 CERTIFICATE

松暉電機工業股份有限公司
SONG HUEI ELECTRIC CO., LTD.
佛山市松暉電機科技有限公司
FOSHAN SONG HUEI ELECTRIC CO., LTD.

一般事項 General	
使用溫度範圍 Operating temperature	-10 °C ~ +70 °C
手工焊接 Manual soldering	300 °C max 3 sec
電氣特性 Electrical Characteristics	
總阻值 (R) Total resistance	10 KΩ
總阻值容許誤差 Total resistance tolerance	± 20 %
阻值線性 Resistance taper	B
摺動雜音 Sliding noise	Less than 100 mV at 20 mm / sec
殘留阻值 Residual resistance	Less than 30 Ω
定格電力 Rated power (W)	0.2 W
額定電壓 Rated voltage (V)	$E = \sqrt{P * R}$ E: Rated voltage 額定電壓 (V) P: Power rating 額定電力 (W) R: Nominal total resistance 公稱全阻抗值 (Ω) 當額定電壓超過最高使用電壓的時候，最高使用電壓即為額定電壓。 When the rated voltage exceeds the maximum operating voltage, the maximum operating voltage shall be the rated voltage.
絕緣阻抗 Insulation resistance	More than 100 MΩ at DC 500 V
耐電壓 Withstand voltage	1 minute at AC 500 V
機械特性 Mechanical Characteristics	
滑動行程 Travel length	60 mm ± 0.5 mm
面板之安裝孔距 Mounting centres	80 mm ± 0.5 mm
滑動力距 Operating force	10 ~ 90 gf.cm
作動止強度 Stopper strength	10 Kgf.cm max
柄的晃動 Lever wobble	2 (2 x L) / 25 mm Max
柄的偏心度 (單側) Lever deviation	0.5 mm max
軸推拉強度 Shaft push-pull strength	5 Kgf max
滑動壽命 Sliding life	15,000 cycles
馬達特性 Motor Performance (8 V DC Motor)	
啟動電流 Starting current	500 mA max
使用電壓 Operating voltage	DC 5 ~ 11 V
馬達回應時間 Motor response time	60 mm travel (60 msec max)



Mounting Hole

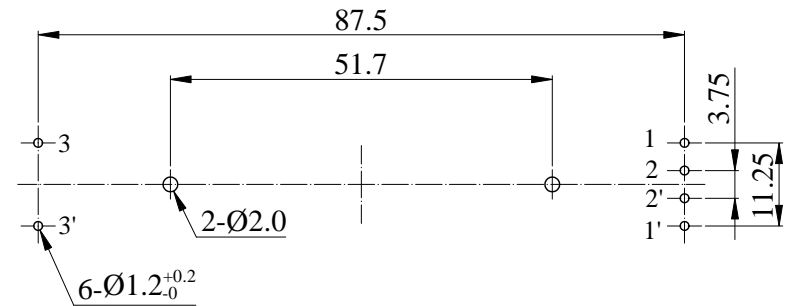

CIRCUIT

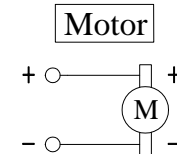
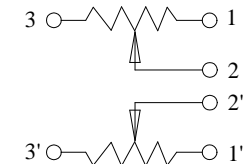
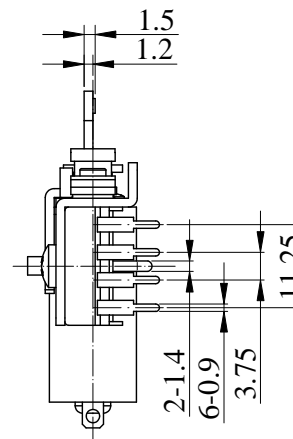

		Non notation tolerance	
	< 10		±0.3
L=	9	10 ~ 100	±0.5
choose		> 100	±0.8

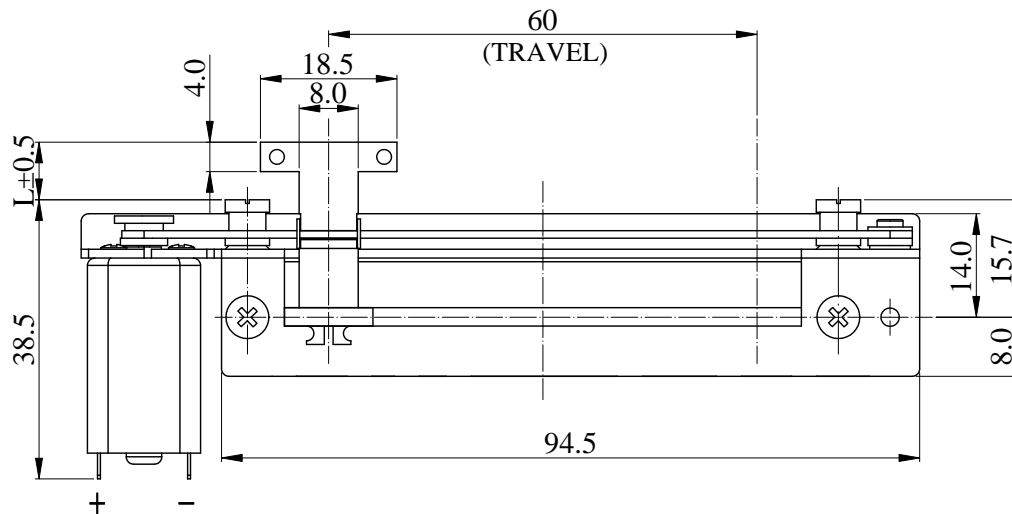

SONG HUEI ELECTRIC CO., LTD.
FOSHAN SONG HUEI ELECTRIC CO., LTD.

MODEL: GSL6092M2(H)/M

Approval



Checked



Projected



UNIT	mm	SCALE	1:1
VERSION	1.1	DATE	2018.08.20
DRAWING NO.	SLV9-036		

	整理图元	何鸿根	2019.01.07
ISSUE	SUBJECT	NAME	DATE

RECORD