

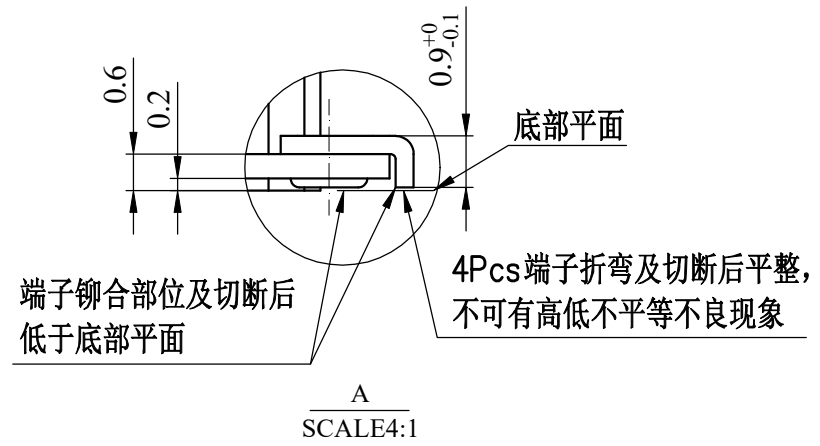

ISO 9001 國際品質認證  
ISO 9001 CERTIFICATE

松暉電機工業股份有限公司  
SONG HUEI ELECTRIC CO., LTD.  
佛山市松暉電機科技有限公司  
FOSHAN SONG HUEI ELECTRIC CO., LTD.

一般事項 General	
使用溫度範圍 Operating temperature	-10 °C ~ +70 °C
儲存溫度 Storage temperature range	-30 °C ~ +80 °C
手工焊接 Manual soldering	300 °C max 3 sec
電氣特性 Electrical Characteristics	
總阻值 (R) Total resistance	5 KΩ
總阻值容許誤差 Total resistance tolerance	± 20 %
阻值線性 Resistance taper	B
摺動雜音 Sliding noise	Less than 100 mV
定格電力 Rated power (W)	0.0125 W
額定電壓 Rated voltage (V)	$E = \sqrt{P * R}$ E: Rated voltage 額定電壓 (V) P: Power rating 額定電力 (W) R: Nominal total resistance 公稱全阻抗值 (Ω) 當額定電壓超過最高使用電壓的時候，最高使用電壓即為額定電壓。 When the rated voltage exceeds the maximum operating voltage, the maximum operating voltage shall be the rated voltage.
最高使用電壓 Max operating voltage	AC 50 V
絕緣阻抗 Insulation resistance	More than 100 MΩ (100 MΩ 以上)
耐電壓 Withstand voltage	1 minute at AC 250 V
機械特性 Mechanical Characteristics	
滑柄使用有效行程 Operating travel of the slide bars	3 mm min (單方向 single direction)
止強度 Stopper strength	500 gf .cm
推拉強度 Push-pull strength	3 Kgf max 3 sec
作動力 Operating force	50 ± 20 gf .cm
工作壽命 Operating life	1,000,000 cycles

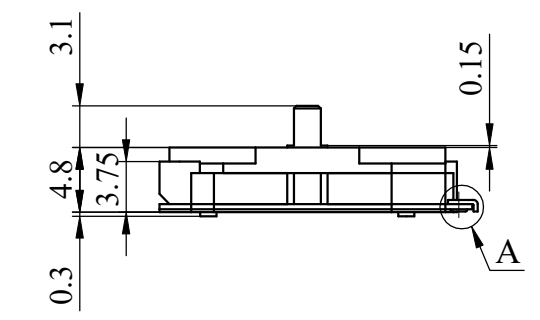
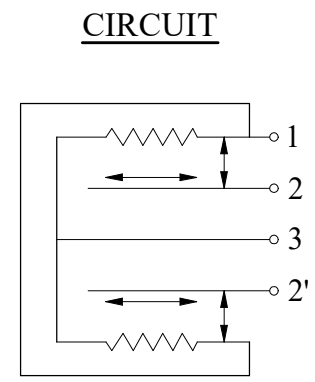
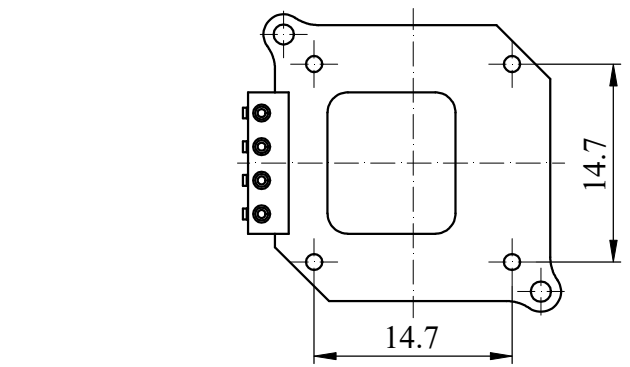
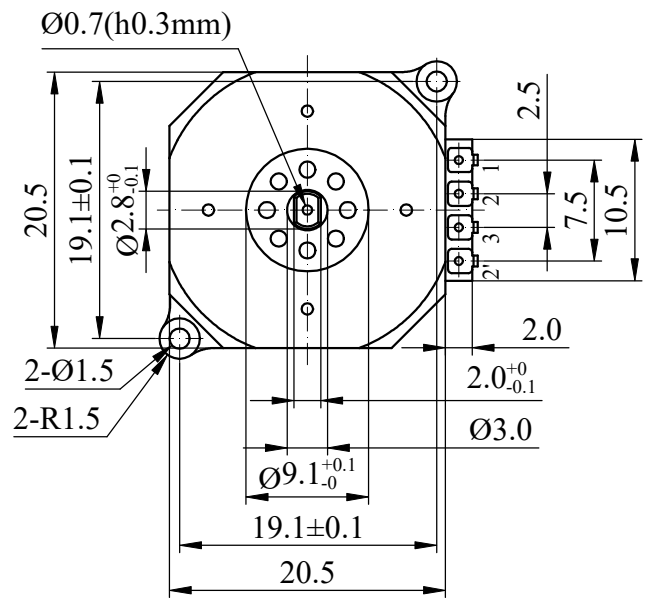

Non notation tolerance	
< 10	±0.3
10 ~ 100	±0.5
> 100	±0.8

**S**® SONG HUEI ELECTRIC CO., LTD.  
FOSHAN SONG HUEI ELECTRIC CO., LTD.

MODEL: J20/0506

△			
△			
△			
△	图元整理	何鸿根	2018.12.26
ISSUE	SUBJECT	NAME	DATE

Approval

**R&D**  
2018-12-26  
藍濬毅

Checked

廠長  
2018-12-26  
鄧記穩

Projected

**R&D**  
2018-12-26  
何鸿根

UNIT	mm	SCALE	2:1
VERSION	1.1	DATE	2018.08.14
DRAWING NO.	SS-087		

RECORD