

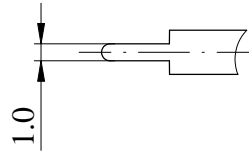

ISO 9001 國際品質認證
ISO 9001 CERTIFICATE

松暉電機工業股份有限公司
SONG HUEI ELECTRIC CO., LTD.
佛山市松暉電機科技有限公司
FOSHAN SONG HUEI ELECTRIC CO., LTD.

一般事項 General	
使用溫度範圍 Operating temperature	-25 °C ~ +70 °C
手工焊接 Manual soldering	300 °C max 3 sec
電氣特性 Electrical Characteristics	
總阻值 (R) Total resistance	Taper A/C: 500Ω ~ 5MΩ ; Taper B: 100 Ω ~ 5 MΩ
總阻值容許誤差 Total resistance tolerance	± 20 % (Lesss than 500 Ω and More than 1 MΩ ± 30 %)
阻值線性 Resistance taper	<input type="checkbox"/> A <input type="checkbox"/> B <input type="checkbox"/> C
接觸阻值變化 Contact resistance variation	< 3% Rn
殘留阻值 Residual resistance	R ≤ 1 KΩ: Less than 20 Ω R > 1 KΩ: Less than 3 % of total resistance value
定格電力 Rated power (W)	Linear (B) taper: 0.25 W Other tapers: 0.13 W
額定電壓 Rated voltage (V)	$E = \sqrt{P * R}$ E: Rated voltage 額定電壓 (V) P: Power rating 額定電力 (W) R: Nominal total resistance 公稱全阻抗值 (Ω) 當額定電壓超過最高使用電壓的時候，最高使用電壓即為額定電壓。 When the rated voltage exceeds the maximum operating voltage,the maximum operating voltage shall be the rated voltage.
最高使用電壓 Max operating voltage	Linear (B) taper: AC 250 V Other tapers: AC 200 V
溫度變化係數 Temperature coefficient	± 500 ppm / °C
機械特性 Mechanical Characteristics	
全回轉角度 Total rotational angle	265 ° ± 5 °
全回扭力 Rotational torque	50 ~ 250 gf.cm
C.C 扭力 C.C torque	<input type="checkbox"/> 50 ~ 250 gf.cm
全回轉止強度 Rotational stopper strength	0.4 Kgf.cm max
回轉壽命 Rotational life	<input type="checkbox"/> Standard: 500 cycles <input type="checkbox"/> Long life: 10,000 cycles

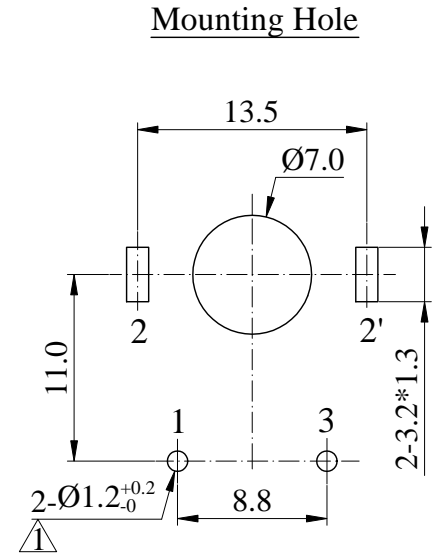
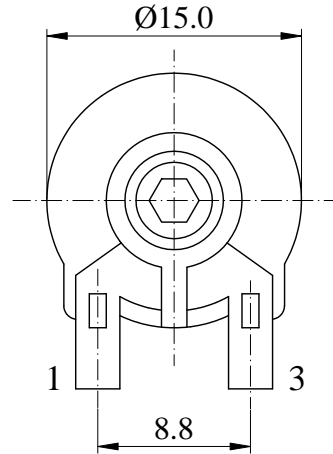
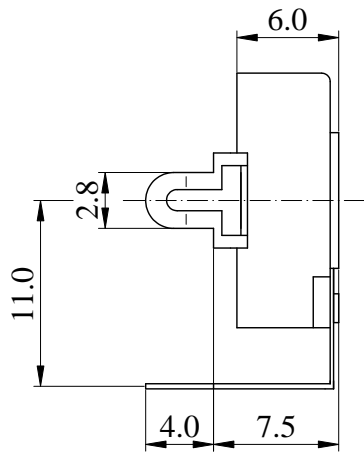

□ L

□ M

□ N

□ G

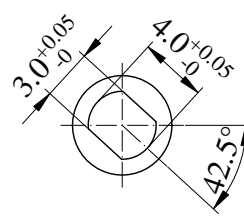
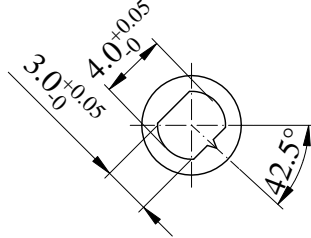
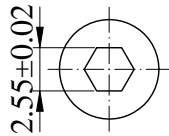
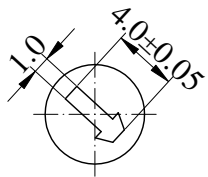

CIRCUIT

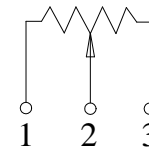

Non notation tolerance	
< 10	±0.3
10 ~ 100	±0.5
> 100	±0.8



SONG HUEI ELECTRIC CO., LTD.
FOSHAN SONG HUEI ELECTRIC CO., LTD.

MODEL: PT15 □D/0091

Approval



Checked



Projected



UNIT	mm	SCALE	2.5:1
VERSION	1.2	DATE	2013.05.02
DRAWING NO.	PT-008		

④			
③			
②	整理图元	何鸿根	2018.12.19
①	增加公差 ^{+0.2} ₋₀	何鸿根	2017.2.20
ISSUE	SUBJECT	NAME	DATE

RECORD