

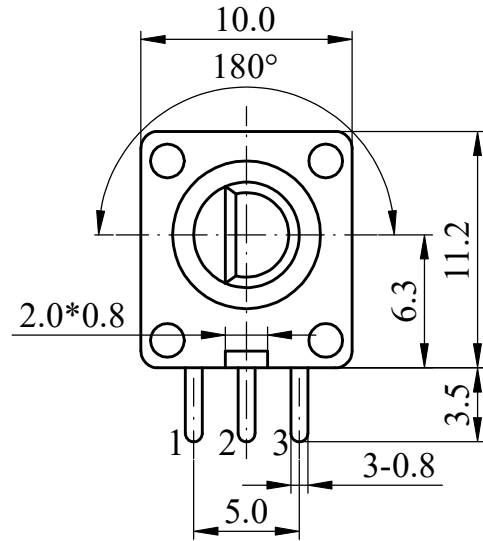

ISO 9001 國際品質認證  
ISO 9001 CERTIFICATE

松暉電機工業股份有限公司  
SONG HUEI ELECTRIC CO., LTD.  
佛山市松暉電機科技有限公司  
FOSHAN SONG HUEI ELECTRIC CO., LTD.

| 一般事項 General                          |  |
|---------------------------------------|--|
| 使用溫度範圍<br>Operating temperature       | -10 °C ~ + 70 °C   |
| 手工焊接<br>Manual soldering              | 300 °C max 3 sec   |
| 電氣特性 Electrical Characteristics       |  |
| 碳膜有效角度<br>Electronic angle            | 75° ± 5°   |
| 總阻值 (R)<br>Total resistance           | 5 KΩ   |
| 總阻值容許誤差<br>Total resistance tolerance | ± 20 %   |
| 阻值線性<br>Resistance taper              | B  |
| 摺動雜音<br>Sliding noise                 | Less than 100 mV   |
| 殘留阻值<br>Residual resistance           | Less than 500 Ω  |
| 定格電力<br>Rated power (W)               | 0.05 W   |
| 額定電壓<br>Rated voltage (V)             | $E = \sqrt{P * R}$<br>E: Rated voltage 額定電壓 (V)<br>P: Power rating 額定電力 (W)<br>R: Nominal total resistance 公稱全阻抗值 (Ω)<br>當額定電壓超過最高使用電壓的時候，最高使用電壓即為額定電壓。<br>When the rated voltage exceeds the maximum operating voltage, the maximum operating voltage shall be the rated voltage. |
| 最高使用電壓<br>Max operating voltage       | AC 50 V DC 12 V  |
| 絕緣阻抗<br>Insulation resistance         | More than 100 MΩ at DC 250 V   |
| 耐電壓<br>Withstand voltage              | 1 minute at AC 250 V   |
| 機械特性 Mechanical Characteristics       |  |
| 全回轉角度<br>Total rotational angle       | 180° ± 5°  |
| 止檔強度<br>Shaft stop strength           | 3 Kgf.cm max   |
| 全回扭力<br>Rotational torque             | 5 ~ 80 gf.cm   |
| 軸推拉強度<br>Shaft push-pull strength     | 4 Kgf max  |
| 回轉壽命<br>Rotational life               | 100,000 cycles   |

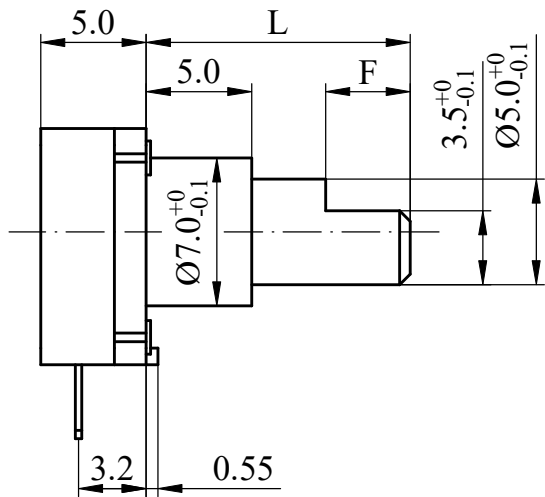

Mounting Hole

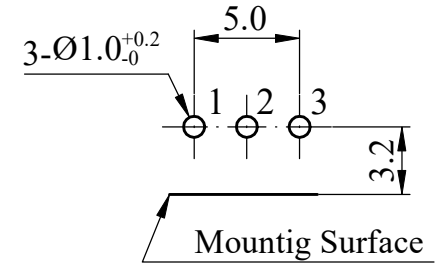

SHAFT SHOWN IN  
FULL C.C.W POSITION

CIRCUIT

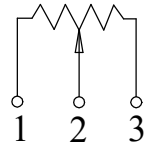

Non notation tolerance

|        |      |      |          |      |
|--------|------|------|----------|------|
| L=     | 10.5 | 12.5 | < 10     | ±0.3 |
| F=     | 5.5  | 4    | 10 ~ 100 | ±0.5 |
| choose |      |      | > 100    | ±0.8 |



SONG HUEI ELECTRIC CO., LTD.  
FOSHAN SONG HUEI ELECTRIC CO., LTD.

MODEL: R0908N(F)/0506



Approval



Checked



Projected



UNIT

mm

SCALE

3:1

VERSION

1.0

DATE

2020.12.30

DRAWING NO.

R09N-060



ISSUE

SUBJECT

NAME

DATE

RECORD