

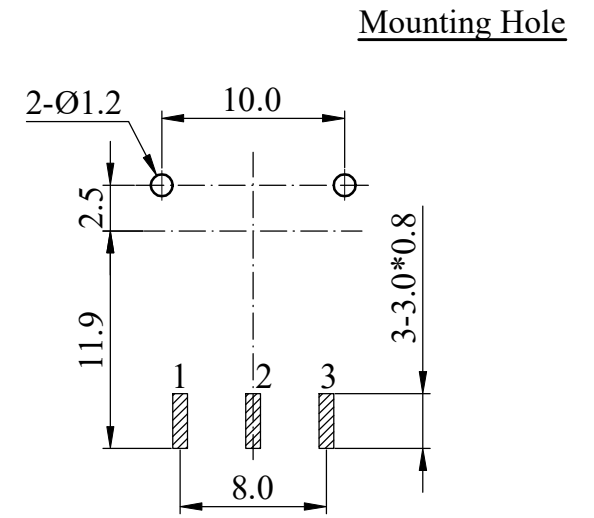

ISO 9001 國際品質認證  
ISO 9001 CERTIFICATE

松暉電機工業股份有限公司  
SONG HUEI ELECTRIC CO., LTD.  
佛山市松暉電機科技有限公司  
FOSHAN SONG HUEI ELECTRIC CO., LTD.

一般事項 General	
使用溫度範圍 Operating temperature	-10 °C ~ +70 °C
手工焊接 Manual soldering	300 °C max 3 sec
電氣特性 Electrical Characteristics	
總阻值 (R) Total resistance	500 Ω ~ 1 MΩ
總阻值容許誤差 Total resistance tolerance	± 20 % (Less than 500 Ω and More than 1 MΩ ± 30 %)
阻值線性 Resistance taper	<input type="checkbox"/> A <input type="checkbox"/> B <input type="checkbox"/> C <input type="checkbox"/> W
摺動雜音 Sliding noise	Less than 100 mV
殘留阻值 Residual resistance	Less than 20 Ω
定格電力 Rated power (W)	0.03 W
額定電壓 Rated voltage (V)	$E = \sqrt{P * R}$ E: Rated voltage 額定電壓 (V) P: Power rating 額定電力 (W) R: Nominal total resistance 公稱全阻抗值 (Ω) 當額定電壓超過最高使用電壓的時候，最高使用電壓即為額定電壓。 When the rated voltage exceeds the maximum operating voltage, the maximum operating voltage shall be the rated voltage.
最高使用電壓 Max operating voltage	AC 50 V / DC 12 V
絕緣阻抗 Insulation resistance	More than 100 MΩ at DC 100 V
耐電壓 Withstand voltage	1 minute at AC 100 V
機械特性 Mechanical Characteristics	
全回轉角度 Total rotational angle	270 ° ± 10 °
全回扭力 Rotational torque	20 ~ 100 gf.cm
全回轉止強度 Rotational stopper strength	0.8 Kgf.cm max
軸推拉強度 Shaft push-pull strength	Push force: 0.5 Kgf max Pull force: 0.2 Kgf max
回轉壽命 Rotational life	10,000 cycles

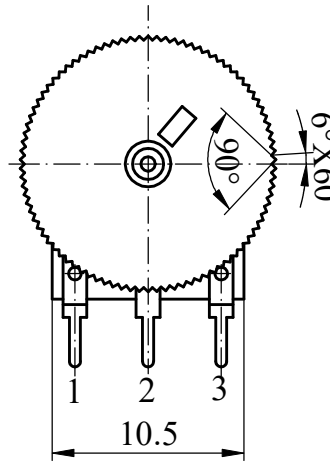
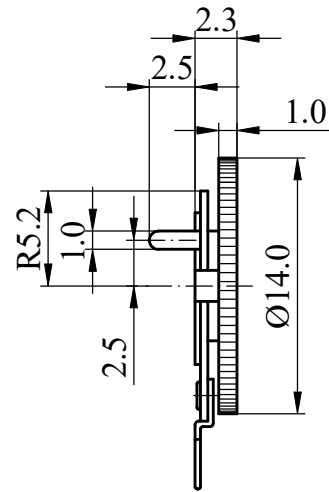
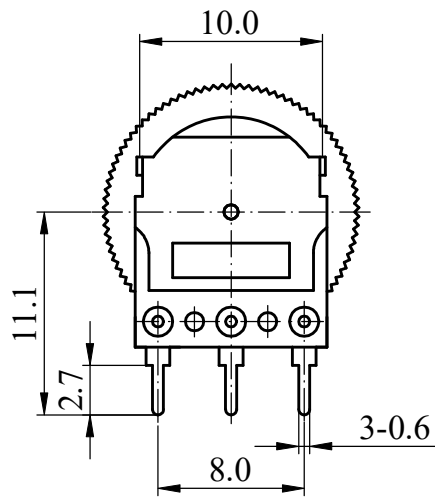

FULL C.C.W POSITION

CIRCUIT

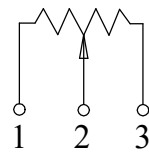

Non notation tolerance	
< 10	±0.3
10 ~ 100	±0.5
> 100	±0.8



SONG HUEI ELECTRIC CO., LTD.  
FOSHAN SONG HUEI ELECTRIC CO., LTD.

MODEL: R1001N12A1/14\*1

Approval



Checked



Projected



UNIT

mm

SCALE

2:1

VERSION

1.1

DATE

2018.05.08

DRAWING NO.

R10N-038

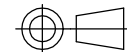

整理图元

何鸿根

2018.12.19

ISSUE

SUBJECT

NAME

DATE

RECORD

# Type of Knob 旋鈕形式:

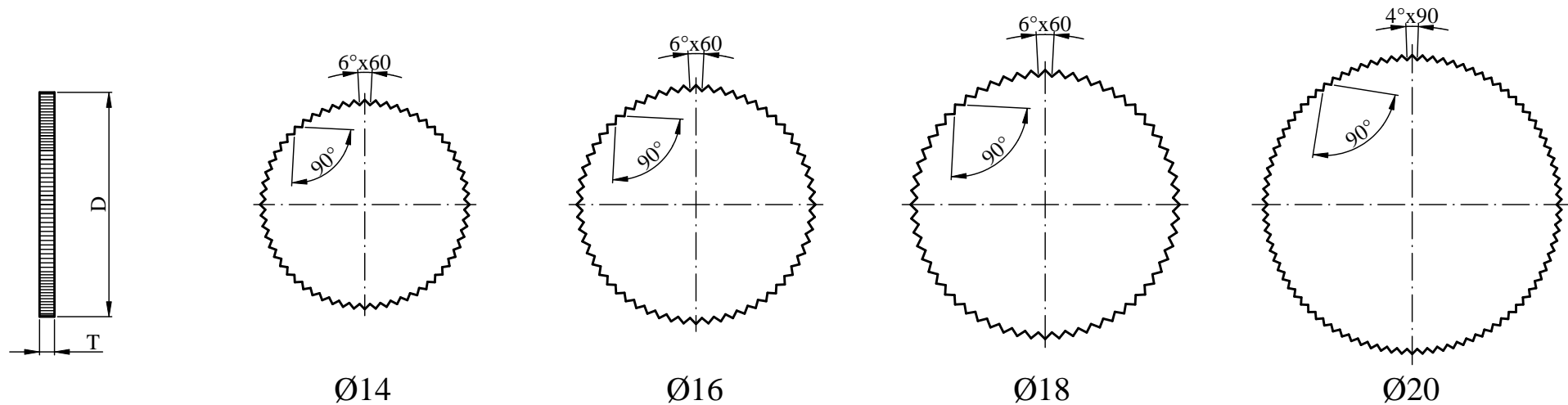

Outside Diameter(D)	Ø14	Ø14	Ø16	Ø16	Ø16	Ø18	Ø18	Ø18	Ø20
Thickness(T)	1.0	2.0	1.0	2.0	2.8	1.0	2.0	2.8	2.0