



ISO 9001 國際品質認證  
ISO 9001 CERTIFICATE

松暉電機工業股份有限公司  
SONG HUEI ELECTRIC CO., LTD.  
佛山市松暉電機科技有限公司  
FOSHAN SONG HUEI ELECTRIC CO., LTD.

一般事項 General

項目 Item	測試條件 Test Conditions	規格 Performance
使用溫度範圍 Operating temperature	-30 °C ~ +80 °C	
標準測試環境為溫度 15 ~ 35 °C 及濕度 25 ~ 85 % RH。 Standard test conditions shall be 15 ~ 35 °C in temperature and 25 ~ 85 % RH in humidity.		
如有判定上的疑慮，測試應該 20 ± 1 °C 及 63 ~ 67 % RH 環境下進行。 Should any doubt arise in judgment test shall be conducted at 20 ± 1 °C and 63 ~ 67 % RH.		

電氣特性 Electrical Characteristics

項目 Item	測試條件 Test Conditions	規格 Performance
開關電路接入點數 Switchcircuitandn umber of pulse		極數 Poles      段數 Sections □1 □2 □3 □4      □2 □3 □4 □5 □6
定格電力 Rating		DC 16 V 0.3 A
絕緣阻抗 Insulation resistance	在端子和支架間施加電壓500V DC 1 分鐘 Measurement shall be made under the condition which a voltage of 500V DC 1 min is applied between individual terminals and frame	More than 100 MΩ 大於 100 MΩ
耐電壓 Withstand voltage	在端子和支架間施加電壓AC500V 電壓1 分鐘 A voltage of 500VAC shall be applied for 1 minute between individual terminals and frame	不可有損傷、電弧、絕緣破壞。 Without damage to parts arcing or breakdown.
接觸電阻 Contact resistance	出力信號處於ON 時安定狀態條件下測定 Measurement shall be stable condition which a Output signal is ON	壽命前：50 mΩ 以下 Initial: 50mΩ max 壽命後：1Ω 以下 After operating life: 1Ω max
轉換時間 Changeover timing	/	Non-shorting

機械特性 Mechanical Characteristics

項目 Item	測試條件 Test Conditions	規格 Performance						
轉換角度 Changeover angle		30° ± 3° (one-step operating angle)						
旋轉力矩 Rotational torque		200-800 gf.cm						
止檔強度 Shaft stopper strength		5 Kgf.cm max 小於 5 Kgf.cm						
軸推拉強度 Push-pull strength of shaft	在軸端，沿軸向施加8Kg 的靜負荷力推和拉各10 秒鐘(產品焊錫固定在PCB 上.) Push and pull static load of 8Kg shall be applied to the shaft in the axial direction for 10s. (After soldering of the PCB board)	8 Kgf.cm max 小於 8 Kgf.cm						
焊錫耐熱性 Soldering heat resistance	<p>※DIP焊錫條件: Condition of DIP soldering: 1.清潔焊錫處理時,請確保在下列條件下作業: 1.Soldering shall be certified with following condition.</p> <table border="1"> <tr> <td>預熱溫度 Preheat temperature</td> <td>印刷基板之 RV 固定面溫度 100 °C 以下，1 分鐘以內。 1.Surface temperature of mounting side 100 °C max within 1 min.</td> </tr> <tr> <td>焊錫溫度 Solder sotemnerature</td> <td>260 °C ± 5 °C 3 秒以內。 260 °C ± 5 °C Within 3 sec</td> </tr> <tr> <td>手焊溫度 Manual solder temperature</td> <td>350 °C ± 5 °C 3 秒以內。 350 °C ± 5 °C Within 3 sec</td> </tr> </table> <p>2.以上工程 1 次通過即可。 2.Please use the above process only one time.</p>	預熱溫度 Preheat temperature	印刷基板之 RV 固定面溫度 100 °C 以下，1 分鐘以內。 1.Surface temperature of mounting side 100 °C max within 1 min.	焊錫溫度 Solder sotemnerature	260 °C ± 5 °C 3 秒以內。 260 °C ± 5 °C Within 3 sec	手焊溫度 Manual solder temperature	350 °C ± 5 °C 3 秒以內。 350 °C ± 5 °C Within 3 sec	不得有絕緣體的破損、變形、接觸無異常 Electrical characteristics shall be satisfied No mechanical abnormality
預熱溫度 Preheat temperature	印刷基板之 RV 固定面溫度 100 °C 以下，1 分鐘以內。 1.Surface temperature of mounting side 100 °C max within 1 min.							
焊錫溫度 Solder sotemnerature	260 °C ± 5 °C 3 秒以內。 260 °C ± 5 °C Within 3 sec							
手焊溫度 Manual solder temperature	350 °C ± 5 °C 3 秒以內。 350 °C ± 5 °C Within 3 sec							



ISO 9001 國際品質認證  
ISO 9001 CERTIFICATE

松暉電機工業股份有限公司  
SONG HUEI ELECTRIC CO., LTD.  
佛山市松暉電機科技有限公司  
FOSHAN SONG HUEI ELECTRIC CO., LTD.

耐久特性 Durability

項目 Item	測試條件 Test Conditions	規格 Performance
操作壽命 Operating life	在無負荷條件下軸以600~1000 周/小時速度回轉, 24 小時連續5000~8000 次。 The shaft of switch shall be rotated at speed of 600~1000 cycles /H without electrical load, after with measurements shall be made (5000 to 8000 continuous cycles for 24 hours.)	10000±200周 10000±200 cycles per below 尚餘有輕微定位感。 端子間接觸阻抗1Ω 以下。 Detent feeling has to remains。 Contact resistance 1Ω Max.

耐候性 Weather Performance

項目 Item	測試條件 Test Conditions	規格 Performance
濕度測試 Humidity test	溫度40±2°C,濕度90~95%的恒溫恒濕槽中放置 96±4 小時後,在常溫、常濕中放置1.5 小時後測試。 The switch shall be stored at temperature of 40±2°C with relative humidity of 90~95% for 96±4 in a thermostatic chamber. And the switch shall be subjected to standard atmospheric conditions for 1.5H, After which measurements shall be made.	所有項應滿足初期規格。 Specifications in clause all items is shall be satisfied.
高溫測試 Heat test	溫度85±3°C,的恒溫箱中放置96±4 小時,常溫、常濕 放置1.5 小時後測試。 The switch shall be stored at a temperature of 85±3°C for 96±4H in a thermostatic chamber, And then the switch . Shall be subjected to standard atmospheric conditions for 1.5H, After which measurements shall be made.	
低溫特性 Cold test	溫度-40±3°C的恒溫箱中放置96±4 小時,常溫、常濕放 置1.5 小時後測試。 The switch shall be stored at a temperature of -40 ±3 °C for 96 ± 4H in a thermostatic chamber, And then the switch . Shall be subjected to standard atmospheric conditions for 1.5H, After which measurements shall be made.	

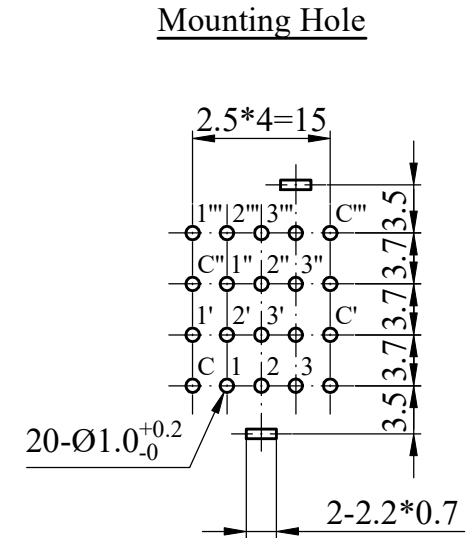
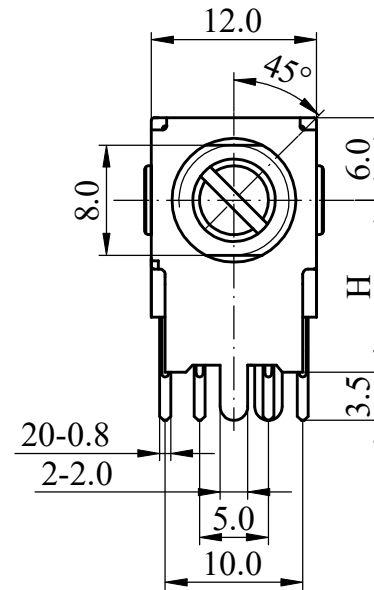
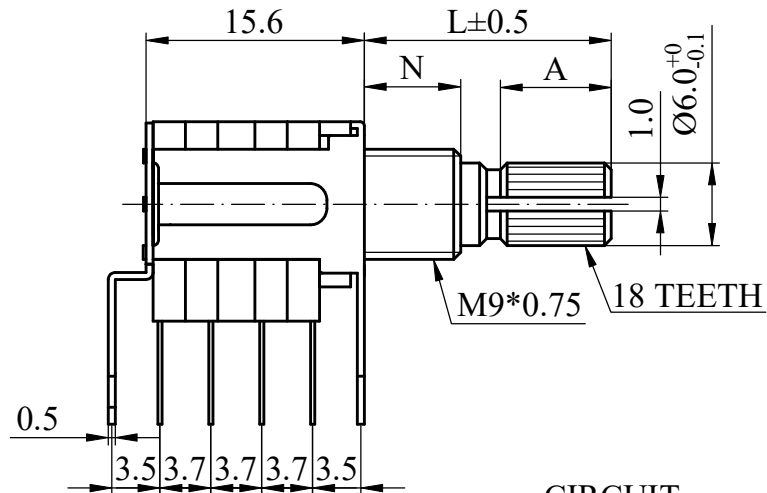

CIRCUIT

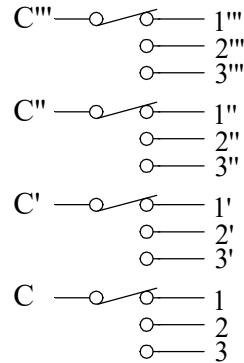

SHAFT SHOWN IN FULL C.W POSITION

N=	<input type="checkbox"/> 5	<input type="checkbox"/> 7		
H=	<input type="checkbox"/> 10	<input type="checkbox"/> 12.5	Non notation tolerance	
L=	15	20	< 10	±0.3
A=	6	9	10 ~ 100	±0.5
choose			> 100	±0.8

**S**® SONG HUEI ELECTRIC CO., LTD.  
FOSHAN SONG HUEI ELECTRIC CO., LTD.

MODEL: RBP12-4-3(KC)/LAL/0496

Approval



Checked



Projected



UNIT	mm	SCALE	1.5:1
VERSION	1.0	DATE	2019.11.08
DRAWING NO.	RS12-004		

ISSUE	SUBJECT	NAME	DATE
RECORD			