



ISO 9001 國際品質認證
ISO 9001 CERTIFICATE

松暉電機工業股份有限公司
SONG HUEI ELECTRIC CO., LTD.
佛山市松暉電機科技有限公司
FOSHAN SONG HUEI ELECTRIC CO., LTD.

一般事項 General								
項目 Item	測試條件 Test Conditions	規格 Performance						
使用溫度範圍 Operating temperature	-10 °C ~ +70 °C							
標準測試環境為溫度 5 ~ 35 °C 及濕度 45 ~ 85 % RH。 Standard test conditions shall be 5 ~ 35 °C in temperature and 45 ~ 85 % RH in humidity.								
如有判定上的疑慮，測試應該 20 ± 2 °C 及 65 ± 5 % RH 環境下進行。 Should any doubt arise in judgment test shall be conducted at 20 ± 2 °C and 65 ± 5 % RH.								
電氣特性 Electrical Characteristics								
項目 Item	測試條件 Test Conditions	規格 Performance						
定格電力 Rating	開關所能承受的最大的電壓和電流。 The switch can take maximum voltage and current.	AC 125 V 0.3 A						
接觸電阻 Contact resistance	使用 1 KHz ± 200 Hz (最大 20 mV, 50 Ma) 或 5 V DC 1 A 壓降法測試。 Shall be measured at 1 KHz ± 200 Hz (Max 20 mV, Max 50 mA) or 5 V DC, 1 A by a voltage drop method.	Less than 50 mΩ 小於 50 mΩ						
絕緣阻抗 Insulation resistance	施加 500 V 之直流電壓，測試 1 分鐘。 測試位置：端子和軸心間。 Shall be measured by applying 500 V DC, between all terminals and between the terminal and the frame for 1 minute ± 5 sec	More than 100 MΩ 大於 100 MΩ						
耐電壓 Withstand voltage	施加 500 V 之交流電壓，測試 1 分鐘。 測試位置：端子和外殼、端子和軸心間。 Applying 500 V AC measure for 1 minute. Applied position: between terminal and frame between terminal and shaft .	不可有損傷、電弧、絕緣破壞 Without damage to parts arcing or breakdown.						
機械特性 Mechanical Characteristics								
項目 Item	測試條件 Test Conditions	規格 Performance						
作動力 Operating force	旋轉速度：30 ° / 秒 操作位置：軸心前端 5 mm 處。 Rotation speed: 30 ° / sec. Operating position: 5 mm from shaft end.	1.0 ± 0.5 kgf.cm						
止檔強度 Shaft stopper strength	測試時間：旋轉至開關起始端和末尾端各 10 ± 1 秒。 Test duration: switch rotate to each end for 10 +/- 1 sec.	5 Kgf.cm max 小於 5 Kgf.cm						
軸推拉強度 Push-pull strength of shaft	測試時間：使用推力 10 秒後立即再使用拉力 20 秒。 測試點及方向：測試點為軸心頂部，方向為軸向。 Apply torsion force for bushing matching nut. Test duration: 10 sec. of push force immediately followed by 20 sec. of pull force should be applied. Test point and direction: the strength should be applied to the top end of the shaft in axial direction.	8 Kgf.cm max 小於 8 Kgf.cm						
焊錫耐熱性 Soldering heat resistance	<p>※DIP焊錫條件：Condition of DIP soldering: 1.清潔焊錫處理時,請確保在下列條件下作業: 1.Soldering shall be certified with following condition.</p> <table border="1"> <tr> <td>預熱溫度 Preheat temperature</td> <td>印刷基板之 RV 固定面溫度 100 °C 以下，2 分鐘以內。 1.Surface temperature of mounting side 100 °C max within 2 min.</td> </tr> <tr> <td>焊錫溫度 Solder sotemnerature</td> <td>260 °C ± 5 °C 5 秒以內。 260 °C ± 5 °C Within 5 sec</td> </tr> <tr> <td>手焊溫度 Manual solder temperature</td> <td>350 °C ± 5 °C 3 秒以內。 350 °C ± 5 °C Within 3 sec</td> </tr> </table> <p>2.以上工程 1 次通過即可。 2.Please use the above process only one time.</p>	預熱溫度 Preheat temperature	印刷基板之 RV 固定面溫度 100 °C 以下，2 分鐘以內。 1.Surface temperature of mounting side 100 °C max within 2 min.	焊錫溫度 Solder sotemnerature	260 °C ± 5 °C 5 秒以內。 260 °C ± 5 °C Within 5 sec	手焊溫度 Manual solder temperature	350 °C ± 5 °C 3 秒以內。 350 °C ± 5 °C Within 3 sec	端子不可有接觸不良或明顯鬆動。 Without excessive looseness of terminals and failure contact.
預熱溫度 Preheat temperature	印刷基板之 RV 固定面溫度 100 °C 以下，2 分鐘以內。 1.Surface temperature of mounting side 100 °C max within 2 min.							
焊錫溫度 Solder sotemnerature	260 °C ± 5 °C 5 秒以內。 260 °C ± 5 °C Within 5 sec							
手焊溫度 Manual solder temperature	350 °C ± 5 °C 3 秒以內。 350 °C ± 5 °C Within 3 sec							



ISO 9001 國際品質認證
ISO 9001 CERTIFICATE

松暉電機工業股份有限公司
SONG HUEI ELECTRIC CO., LTD.
佛山市松暉電機科技有限公司
FOSHAN SONG HUEI ELECTRIC CO., LTD.

耐久特性 Durability		
項目 Item	測試條件 Test Conditions	規格 Performance
操作壽命 (無負載) Operating life (Under no load)	10, 000 個週期, 運行期間不間斷, 運行速度每分鐘 9 ~ 12 次。 10,000 cycles of operating shall be performed continuously at a rate of 9 ~ 12 cycles per minute without load. After operating life test, shall be in accordance with the following specifications.	接觸阻抗小於 200 mΩ。 絕緣電阻大於 50 MΩ。 耐電壓 250 V AC 測試一分鐘 操作力不超出 +10 % ~ -30 % 初始力。 To contact resistance: Less than 200 mΩ. Insulation resistance: More than 50 MΩ. Withstand voltage: 250 V AC per 1 minute. Operating force: Less than +10 % ~ -30 % for initial operating force.
操作壽命 (負載) Operating life (Under load)	10, 000 個週期, 運行期間不間斷, 運行速度每分鐘 9 ~ 12 次, 使用 AC 125 V 0.3 A 的負載進行。 10,000 cycles of operating shall be performed continuously at a rate of 9 ~ 12 cycles per minute with resistive load of AC 125 V 0.3 A. After operating life test, shall be in accordance with the following specifications.	接觸阻抗小於 500 mΩ。 絕緣電阻大於 50 MΩ。 耐電壓 250 V AC 測試一分鐘 操作力不超出 +10 % ~ -30 % 初始力。 To contact resistance: Less than 500 mΩ. Insulation resistance: More than 50 MΩ. Withstand voltage: 250 V AC per 1 minute. Operating force: Less than +10 % ~ -30 % for initial operating force.
耐候性 Weather Performance		
項目 Item	測試條件 Test Conditions	規格 Performance
濕度測試 Humidity test	使用溫度 40 ± 2 °C, 濕度 90 ~ 95 % RH 的測試條件 240 小時後, 放置在常溫下一小時後進行測試。 Testing potentiometers been placed at 40 ± 2 °C and 90~95%RH for 240 hours in anormal ambient condition for an hour. Then to be measured within an hour.	通過以上的測試, 該產品能達到以下要求: 絕緣測試: DC 500 V 電壓。 不小於 50 MΩ。
高溫測試 Heat test	使用溫度 70 ± 2 °C 的測試條件 16 小時後, 放置在常溫下一小時後進行測試。 Testing potentiometers been placed at 70 ± 2 °C in temperature for 16 hours in anormal ambient condition for an hour. Then to be measured within an hour.	耐電壓測試: 使用 AC 250 V 電壓, 測試一分鐘, 不可有損傷、電弧、絕緣破壞, 其他規格要求變化小於 ± 20 %。 Through the above tests, the product can achieve insulation resistance : More than 50 MΩ at 500 V DC.withstand voltage: for 1 minute or more at 250 V AC, without damage to parts arcing or breakdown.other requirements change less than ± 20 %.
低溫特性 Cold test	使用溫度 -10 ± 2 °C 的測試條件 16 小時後, 放置在常溫下一小時後進行測試。 Testing potentiometers been placed at -10 ± 2 °C in temperature for 16 hours in anormal ambient condition for an hour. Then to be measured within an hour.	

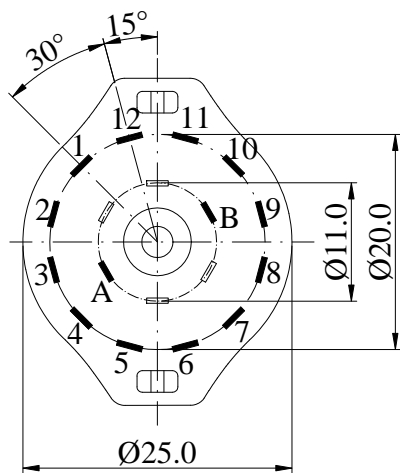

Mounting Hole

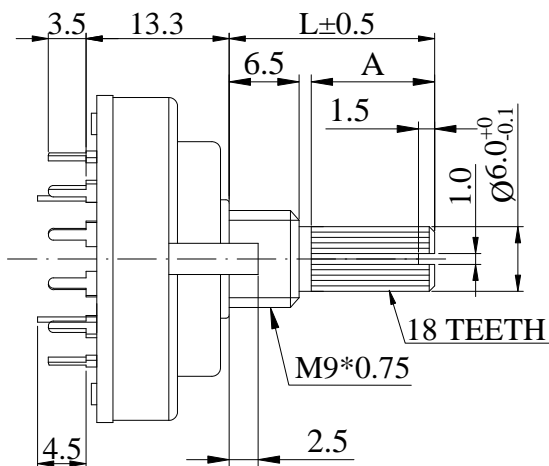

CIRCUIT

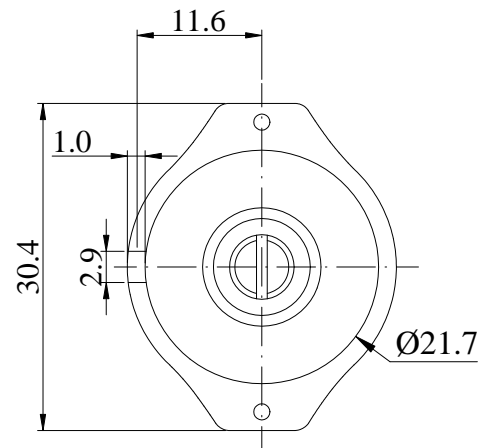

SHAFT SHOW IN FULL C.C.W POSITION

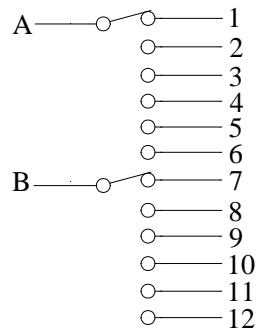
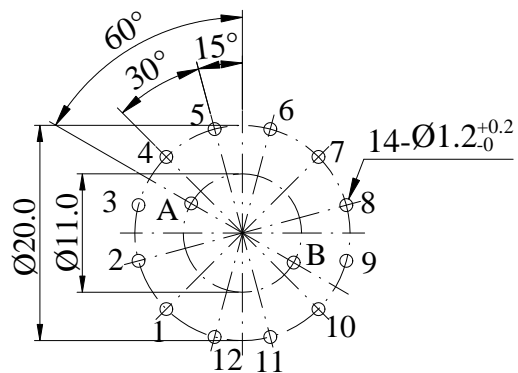

Non notation tolerance

L=	15	20			< 10	±0.3
A=	7	12			10 ~ 100	±0.5
choose					> 100	±0.8



SONG HUEI ELECTRIC CO., LTD.
FOSHAN SONG HUEI ELECTRIC CO., LTD.

MODEL: RBP255-1-2-6(KC)/PH/0081

Approval



Checked



Projected



UNIT

mm

SCALE

1.5:1

VERSION

1.1

DATE

2015.06.23

DRAWING NO.

RS25-156

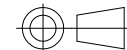

整理图元

何鸿根

2019.01.09

ISSUE

SUBJECT

NAME

DATE

RECORD

Shaft Types 軸型:

KC/PH type					F/PH type				
L	15	20			L	15	20		
A	7	12			F	7	12		