

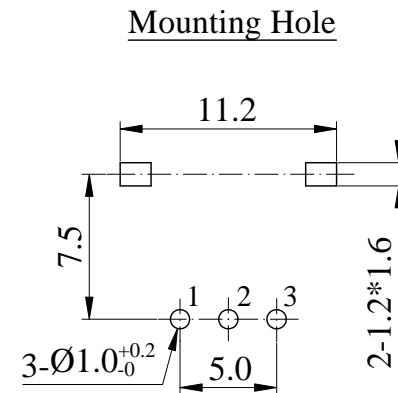

ISO 9001 國際品質認證
ISO 9001 CERTIFICATE

松暉電機工業股份有限公司
SONG HUEI ELECTRIC CO., LTD.
佛山市松暉電機科技有限公司
FOSHAN SONG HUEI ELECTRIC CO., LTD.

一般事項 General	
使用溫度範圍 Operating temperature	-10 °C ~ +70 °C
手工焊接 Manual soldering	260 °C max 3 sec
電氣特性 Electrical Characteristics	
總阻值 (R) Total resistance	1 KΩ ~ 1 MΩ
總阻值容許誤差 Total resistance tolerance	± 20 % (More than 1 MΩ ± 30 %)
阻值線性 Resistance taper	<input type="checkbox"/> A <input type="checkbox"/> B <input type="checkbox"/> C <input type="checkbox"/> W
摺動雜音 Sliding noise	Less than 68 mV
殘留阻值 Residual resistance	Less than 20 Ω
定格電力 Rated power (W)	0.05 W
額定電壓 Rated voltage (V)	$E = \sqrt{P * R}$ E: Rated voltage 額定電壓 (V) P: Power rating 額定電力 (W) R: Nominal total resistance 公稱全阻抗值 (Ω) 當額定電壓超過最高使用電壓的時候，最高使用電壓即為額定電壓。 When the rated voltage exceeds the maximum operating voltage, the maximum operating voltage shall be the rated voltage.
最高使用電壓 Max operating voltage	AC 50 V
絕緣阻抗 Insulation resistance	More than 100 MΩ at DC 250 V
耐電壓 Withstand voltage	1 minute at AC 300 V
機械特性 Mechanical Characteristics	
全回轉角度 Total rotational angle	300 ° ± 5 °
全回扭力 Rotational torque	20 ~ 250 gf.cm
C.C 扭力 C.C torque	<input type="checkbox"/> 50 ~ 150 gf.cm
全回轉止強度 Rotational stopper strength	4 Kgf.cm max
軸推拉強度 Shaft push-pull strength	8 Kgf max
回轉壽命 Rotational life	10,000 cycles

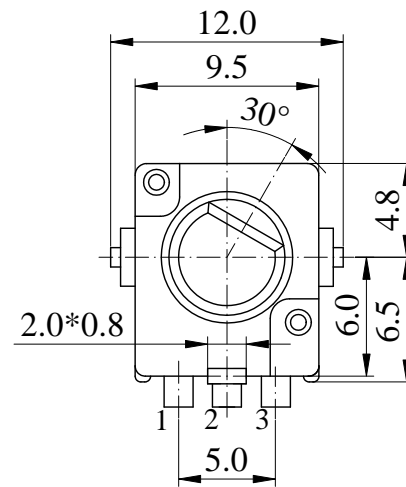
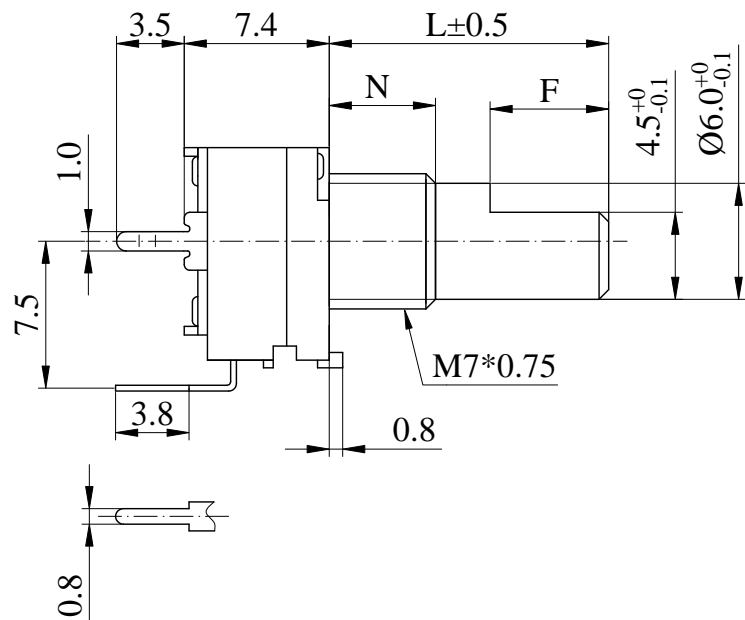

SHAFT SHOWN IN FULL C.C.W POSITION

CIRCUIT

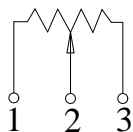

	N=5		N=7			Non notation tolerance	
L=	15		15	17	20	< 10	±0.3
F=	7		7	7	12	10 ~ 100	±0.5
choose						> 100	±0.8



SONG HUEI ELECTRIC CO., LTD.
FOSHAN SONG HUEI ELECTRIC CO., LTD.

MODEL: RK0952N(F)/CI/0083

Approval



Checked



Projected



UNIT

mm

SCALE

3:1

VERSION

1.1

DATE

2017.11.07

DRAWING NO.

R-09KT-123



④			
③			
②			
①	整理图元	何鸿根	2018.12.20
ISSUE	SUBJECT	NAME	DATE

RECORD

Shaft Types 軸型:

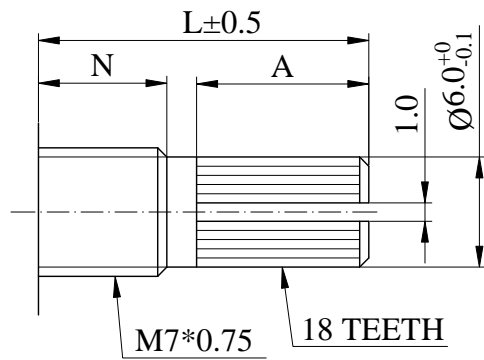

KC Type
N=5mm

L=	10	12.5	15	20
A=	3.8	6	8.5	13.5

N=7mm

L=	12.5	15	20
A=	4	6.5	12

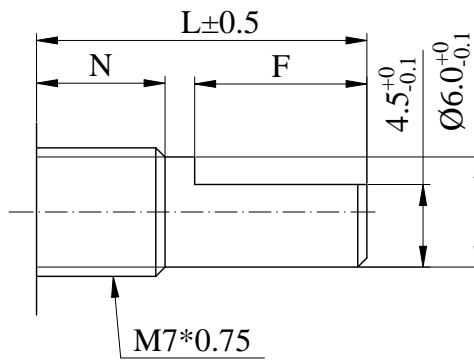

F Type
N=5mm

L=	10	12.5	15	20	25	30
F=	4	7	7	12	12	12

N=7mm

L=	15	20	25	25
F=	7	12	12	12

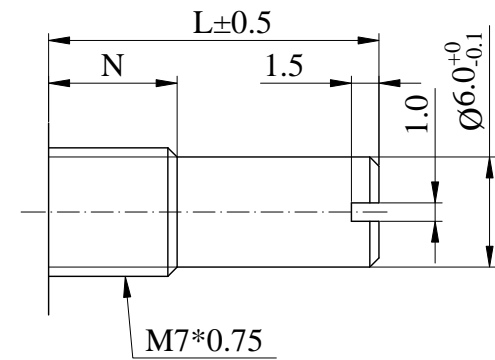

RE Type
N=5mm

L=	8	10	15
----	---	----	----

N=7mm

L=	15
----	----