

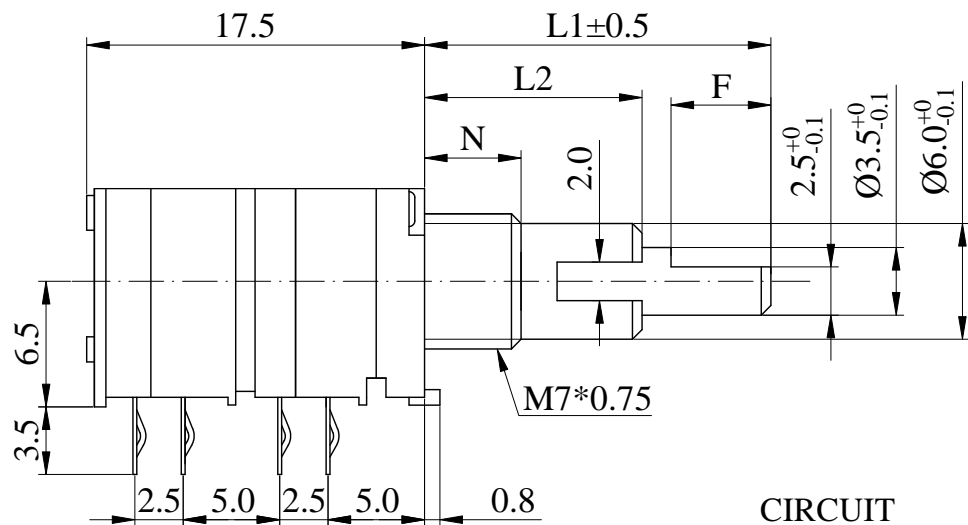

ISO 9001 國際品質認證
ISO 9001 CERTIFICATE

松暉電機工業股份有限公司
SONG HUEI ELECTRIC CO., LTD.
佛山市松暉電機科技有限公司
FOSHAN SONG HUEI ELECTRIC CO., LTD.

一般事項 General	
使用溫度範圍 Operating temperature	-10 °C ~ +70 °C
手工焊接 Manual soldering	260 °C max 3 sec
電氣特性 Electrical Characteristics	
總阻值 (R) Total resistance	1KΩ ~ 500 KΩ
總阻值容許誤差 Total resistance tolerance	± 20 %
阻值線性 Resistance taper	A <input type="checkbox"/> B <input type="checkbox"/> C <input type="checkbox"/> MN <input type="checkbox"/>
摺動雜音 Sliding noise	Less than 100 mV
殘留阻值 Residual resistance	R ≤ 10 KΩ : Less than 20 Ω, 10 KΩ < R ≤ 50 KΩ : Less than 30 Ω , 50 KΩ ≤ R : Less than 1 % of total resistance value
定格電力 Rated power (W)	0.05 W
額定電壓 Rated voltage (V)	$E = \sqrt{P * R}$ E: Rated voltage 額定電壓 (V) P: Power rating 額定電力 (W) R: Nominal total resistance 公稱全阻抗值 (Ω) 當額定電壓超過最高使用電壓的時候，最高使用電壓即為額定電壓。 When the rated voltage exceeds the maximum operating voltage, the maximum operating voltage shall be the rated voltage.
最高使用電壓 Max operating voltage	AC 50 V / DC 10 V
絕緣阻抗 Insulation resistance	More than 100 MΩ at DC 250 V
耐電壓 Withstand voltage	1 minute at AC 300 V
機械特性 Mechanical Characteristics	
全回轉角度 Total rotational angle	300 ° ± 5 °
全回扭力 Rotational torque	20 ~ 250 gf.cm
C.C 扭力 C.C torque	<input type="checkbox"/> 30 ~ 250 gf.cm
全回轉止強度 Rotational stopper strength	5 Kgf.cm
軸推拉強度 Shaft push-pull strength	10 Kgf max
回轉壽命 Rotational life	15,000 cycles



CIRCUIT

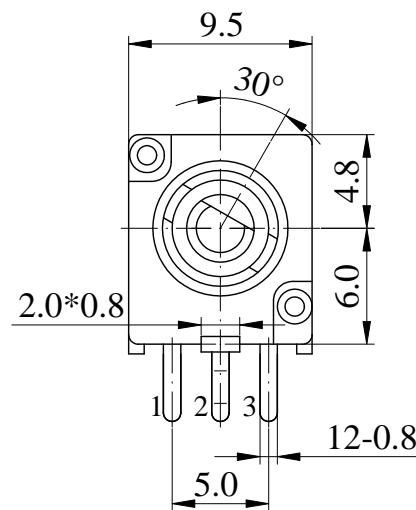
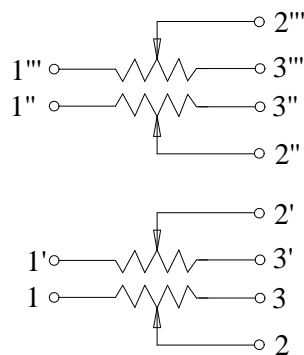

SHAFT SHOWN IN FULL C.C.W POSITION

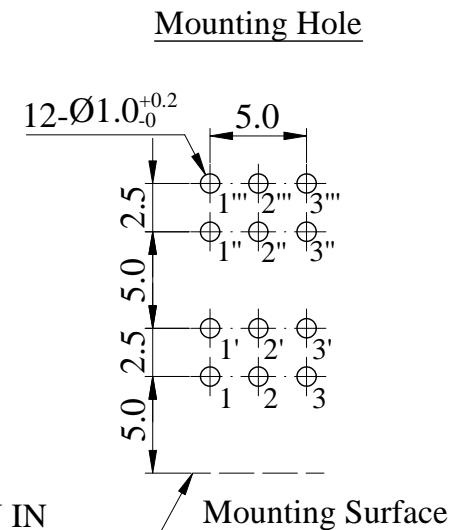

N=	□ 5	□ 7		
L1=	20 25	25 30	Non notation tolerance	
L2=	10 13	15 20	< 10	±0.3
F=	6 8	7 8	10 ~ 100	±0.5
choose			> 100	±0.8



SONG HUEI ELECTRIC CO., LTD.
FOSHAN SONG HUEI ELECTRIC CO., LTD.

MODEL: RK09742(F)/0239

Approval



Checked



Projected



UNIT	mm	SCALE	2:1
VERSION	1.1	DATE	2018.07.27
DRAWING NO.	R-09KT-145		

④			
③			
②			
①	整理图元	何鸿根	2018.12.21
ISSUE	SUBJECT	NAME	DATE
RECORD			