



ISO 9001 國際品質認證
ISO 9001 CERTIFICATE

松暉電機工業股份有限公司
SONG HUEI ELECTRIC CO., LTD.
佛山市松暉電機科技有限公司
FOSHAN SONG HUEI ELECTRIC CO., LTD.

一般事項 General

使用溫度範圍 Operating temperature	-20 °C ~ +70 °C
手工焊接 Manual soldering	260 °C max 3 sec
電氣特性 Electrical Characteristics	
總阻值 (R) Total resistance	1 KΩ ~ 1 MΩ
總阻值容許誤差 Total resistance tolerance	± 20 % (More than 1 MΩ ± 30 %)
阻值線性 Resistance taper	□ A □ B
摺動雜音 Sliding noise	Less than 68 mV
殘留阻值 Residual resistance	Less than 20 Ω
定格電力 Rated power (W)	0.05 W
額定電壓 Rated voltage (V)	$E = \sqrt{P * R}$ E: Rated voltage 額定電壓 (V) P: Power rating 額定電力 (W) R: Nominal total resistance 公稱全阻抗值 (Ω) 當額定電壓超過最高使用電壓的時候，最高使用電壓即為額定電壓。 When the rated voltage exceeds the maximum operating voltage, the maximum operating voltage shall be the rated voltage.
最高使用電壓 Max operating voltage	AC 50 V
絕緣阻抗 Insulation resistance	More than 100 MΩ at DC 300 V
耐電壓 Withstand voltage	1 minute at AC 250V
相互偏差 Gang error	Linear (B) taper: -20 dB ~ 0 dB ≤ 2 dB A/C other tapers: -40 dB ~ 0 dB ≤ 3 dB
機械特性 Mechanical Characteristics	
全回轉角度 Total rotational angle	300 ° ± 5 °
全回扭力 Rotational torque	20 ~ 200 gf.cm
全回轉止強度 Rotational stopper strength	3 Kgf.cm max
軸推拉強度 Shaft push-pull strength	4 Kgf max
回轉壽命 Rotational life	10,000 cycles



ISO 9001 國際品質認證
ISO 9001 CERTIFICATE

松 暉 電 機 工 業 股 份 有 限 公 司
SONG HUEI ELECTRIC CO., LTD.
佛 山 市 松 暉 電 機 科 技 有 限 公 司
FOSHAN SONG HUEI ELECTRIC CO., LTD.

LED特性:								
LED Characteristic:								
选项	发光色	项目	记号	试验条件	以上	标准值	以下	单位
Choice	Emitted color	Item	Symbol	Test conditions	Min	Typ	Max	Unit
	白色 White	直流顺电压 Forward voltage	VF	IF=20mA	2.7	3.2	3.4	V
		亮度 Luminous intensity	IV	IF=20mA	1000	—	1500	mcd
	绿色 Green	直流顺电压 Forward voltage	VF	IF=20mA	2.7	3.2	3.4	V
		亮度 Luminous intensity	IV	IF=20mA	800	—	1500	mcd
	红色 Red	直流顺电压 Forward voltage	VF	IF=20mA	1.7	—	2.4	V
		亮度 Luminous intensity	IV	IF=20mA	100	—	300	mcd
	蓝色 Blue	直流顺电压 Forward voltage	VF	IF=20mA	2.7	3.2	3.4	V
		亮度 Luminous intensity	IV	IF=20mA	200	—	350	mcd

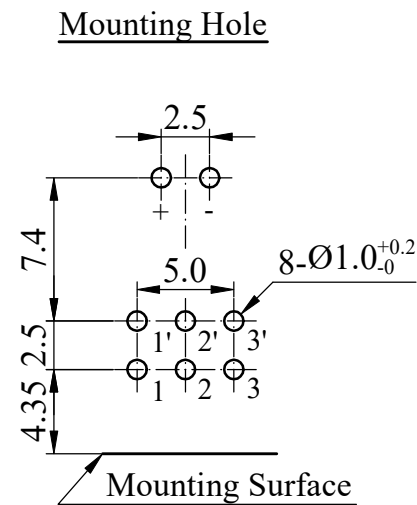
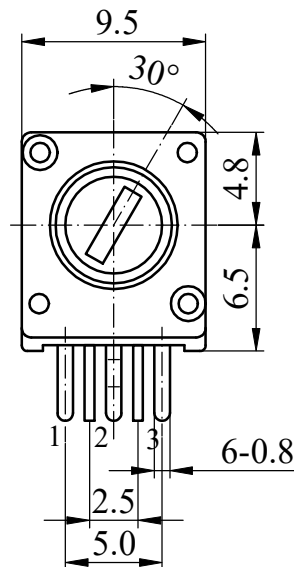
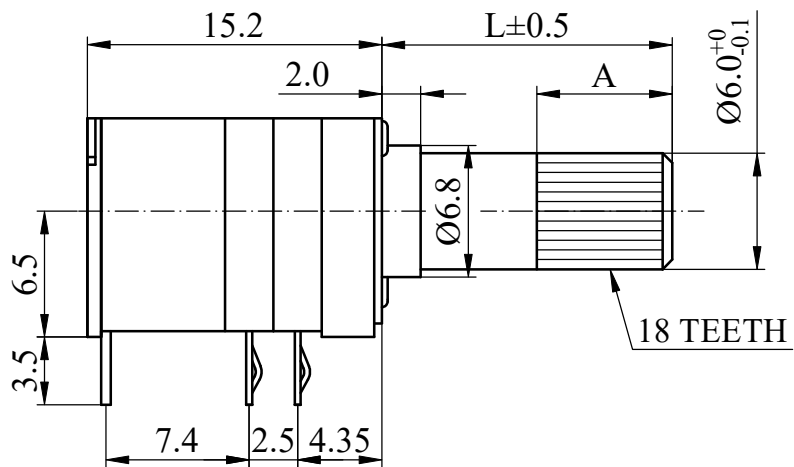

CIRCUIT

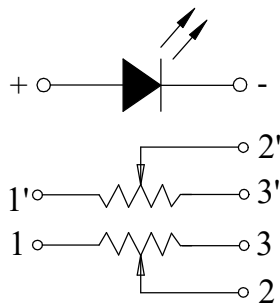

SHAFT SHOWN IN FULL C.C.W POSITION

L=	10	15		Non notation tolerance	
A=	7	7		< 10	±0.3
choose				10 ~ 100	±0.5
				> 100	±0.8

LED	White	Red	Blue	10 ~ 100	±0.5
choose				> 100	±0.8

S® SONG HUEI ELECTRIC CO., LTD.
FOSHAN SONG HUEI ELECTRIC CO., LTD.

MODEL: RK0992(LED)/0083

Approval	Checked	Projected

UNIT	mm	SCALE	2:1
VERSION	1.1	DATE	2019.10.23
DRAWING NO.	R-09KT-167		

	增加L=10,A=7	何鴻根	2021.06.11
ISSUE	SUBJECT	NAME	DATE
RECORD			