

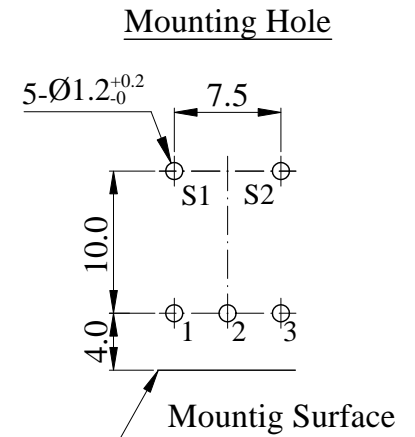

ISO 9001 國際品質認證
ISO 9001 CERTIFICATE

松暉電機工業股份有限公司
SONG HUEI ELECTRIC CO., LTD.
佛山市松暉電機科技有限公司
FOSHAN SONG HUEI ELECTRIC CO., LTD.

一般事項 General	
使用溫度範圍 Operating temperature	-10 °C ~ +70 °C
手工焊接 Manual soldering	260 °C max 3 sec
電氣特性 Electrical Characteristics	
總阻值 (R) Total resistance	1 KΩ ~ 500 KΩ
總阻值容許誤差 Total resistance tolerance	± 20 % (More than 1 MΩ ± 30 %)
阻值線性 Resistance taper	<input type="checkbox"/> A <input type="checkbox"/> B <input type="checkbox"/> C <input type="checkbox"/> D <input type="checkbox"/> W
摺動雜音 Sliding noise	Less than 47 mV (Taper A / C / W : 80 mV)
殘留阻值 Residual resistance	Less than 20 Ω
開關接觸電阻 Switch contact resistance	Less than 50 mΩ
定格電力 Rated power (W)	Linear (B) taper: 0.1 W Other tapers: 0.05 W
開關定格電力 Switch rated power	DC 12 V / 1 A
額定電壓 Rated voltage (V)	$E = \sqrt{P * R}$ E: Rated voltage 額定電壓 (V) P: Power rating 額定電力 (W) R: Nominal total resistance 公稱全阻抗值 (Ω) 當額定電壓超過最高使用電壓的時候，最高使用電壓即為額定電壓。 When the rated voltage exceeds the maximum operating voltage, the maximum operating voltage shall be the rated voltage.
最高使用電壓 Max operating voltage	30 V AC / DC
絕緣阻抗 Insulation resistance	More than 100 MΩ at DC 250 V
耐電壓 Withstand voltage	1 minute at AC 300 V
相互偏差 Gang error	-40 dB ~ 0 dB ≤ 3 dB
機械特性 Mechanical Characteristics	
全回轉角度 Total rotational angle	300 ° ± 10 ° (開關角度 Switch angle: 35 ° ± 5 °)
全回扭力 Rotational torque	20 ~ 200 gf.cm
開關扭力 Switch action	150 ~ 300 gf.cm
全回轉止強度 Rotational stopper strength	3 Kgf.cm max
軸推拉強度 Shaft push-pull strength	8 Kgf max
回轉壽命 Rotational life	15,000 cycles (開關壽命 Switch life: 10,000 cycles)

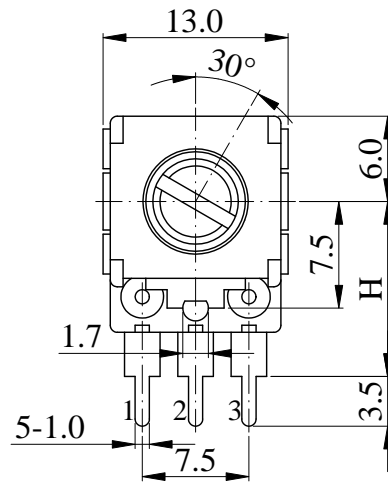
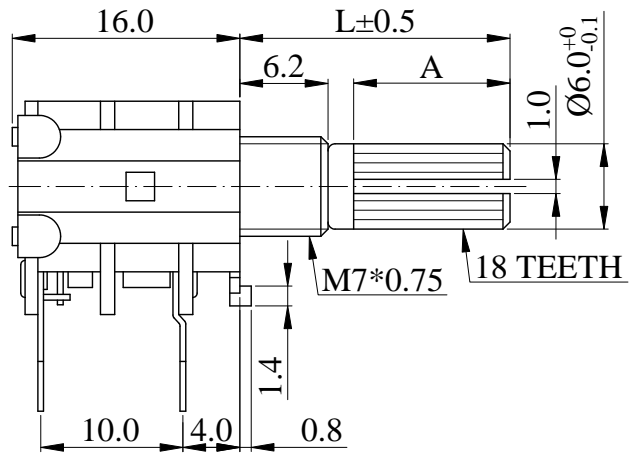

SHAFT SHOWN IN FULL C.C.W POSITION

△ CIRCUIT

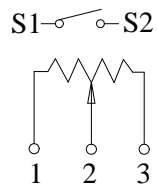

H=	<input type="checkbox"/> 10	<input type="checkbox"/> 12.5	Non notation tolerance			
L=	15	20	25	30	< 10	±0.3
A=	7	12	12	12	10 ~ 100	±0.5
choose					> 100	±0.8

S® SONG HUEI ELECTRIC CO., LTD.
FOSHAN SONG HUEI ELECTRIC CO., LTD.

MODEL: RK1221S(KC)/CI/0083

Approval
R&D
2018-12-26
藍濬毅

Checked
廠長
2018-12-26
鄧記穩

Projected
R&D
2018-12-26
何鴻根

UNIT	mm	SCALE	3:1
VERSION	1.1	DATE	2010.11.08
DRAWING NO.	R122-001		

△			
△			
△			
△	图元整理	何鸿根	2018.12.26
ISSUE	SUBJECT	NAME	DATE

RECORD