

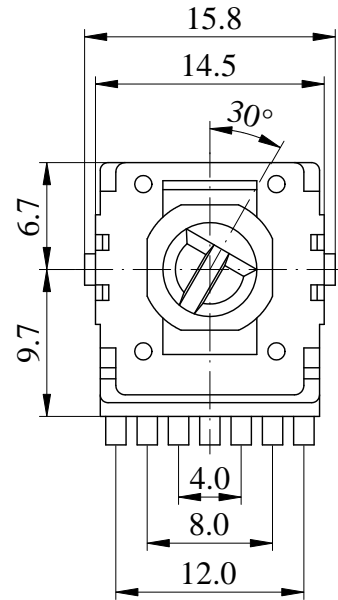

ISO 9001 國際品質認證
ISO 9001 CERTIFICATE

松暉電機工業股份有限公司
SONG HUEI ELECTRIC CO., LTD.
佛山市松暉電機科技有限公司
FOSHAN SONG HUEI ELECTRIC CO., LTD.

一般事項 General	
使用溫度範圍 Operating temperature	-10 °C ~ +70 °C
手工焊接 Manual soldering	300 °C max 3 sec
電氣特性 Electrical Characteristics	
總阻值 (R) Total resistance	5 KΩ ~ 1MΩ
總阻值容許誤差 Total resistance tolerance	± 20 % (More than 1 MΩ ± 30 %)
阻值線性 Resistance taper	A □ B □ C □
摺動雜音 Sliding noise	Less than 80 mV
殘留阻值 Residual resistance	Less than 20 Ω
定格電力 Rated power (W)	0.05 W
額定電壓 Rated voltage (V)	$E = \sqrt{P * R}$ E: Rated voltage 額定電壓 (V) P: Power rating 額定電力 (W) R: Nominal total resistance 公稱全阻抗值 (Ω) 當額定電壓超過最高使用電壓的時候，最高使用電壓即為額定電壓。 When the rated voltage exceeds the maximum operating voltage, the maximum operating voltage shall be the rated voltage.
最高使用電壓 Max operating voltage	AC 50 V (for AC only)
絕緣阻抗 Insulation resistance	More than 100 MΩ at DC 250 V
耐電壓 Withstand voltage	1 minute at AC 300 V
相互偏差 Gang error	-40 dB ~ 0 dB ≤ 3 dB
機械特性 Mechanical Characteristics	
全回轉角度 Total rotational angle	300 ° ± 5 °
全回扭力 Rotational torque	15 ~ 150 gf.cm
C.C 扭力 C.C torque	□ 50 ~ 150 gf.cm
全回轉止強度 Rotational stopper strength	6 Kgf.cm max
軸推拉強度 Shaft push-pull strength	8 Kgf max
回轉壽命 Rotational life	15,000 cycles

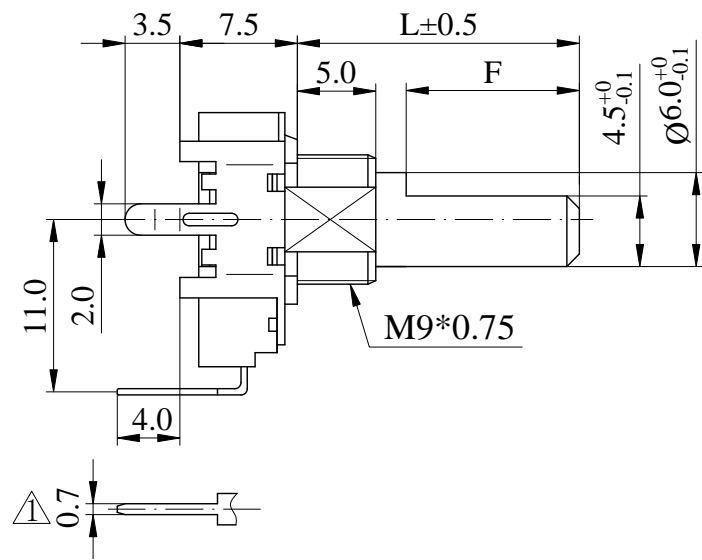

SHAFT SHOWN IN FULL C.C.W POSITION

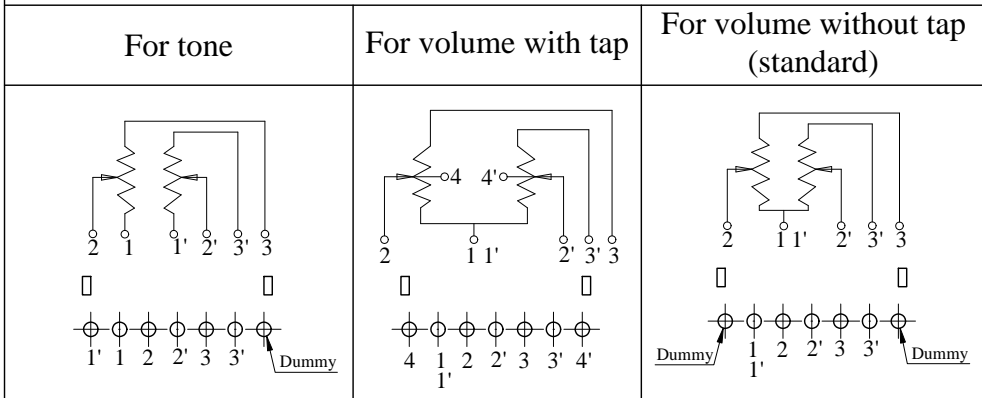
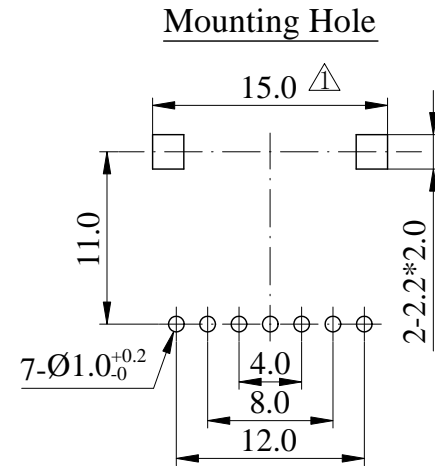

								Non notation tolerance		
L=	12.5	15	17.5	20	22.5	25	27.5	30	< 10	±0.3
F=	7	7	12	12	12	12	12	12	10 ~ 100	±0.5
choose									> 100	±0.8

S® SONG HUEI ELECTRIC CO., LTD.
FOSHAN SONG HUEI ELECTRIC CO., LTD.

MODEL: RK1414G(F)

Approval	Checked	Projected

UNIT	mm	SCALE	2:1
VERSION	1.2	DATE	2011.12.26
DRAWING NO.	R14G-008		

	整理图元	何鸿根	2018.12.24
	修改电路图, 修改标注位置, 增加端子	张丽娜	2012-2-8
ISSUE	SUBJECT	NAME	DATE
RECORD			

Shaft Types 軸型:

Horizontal

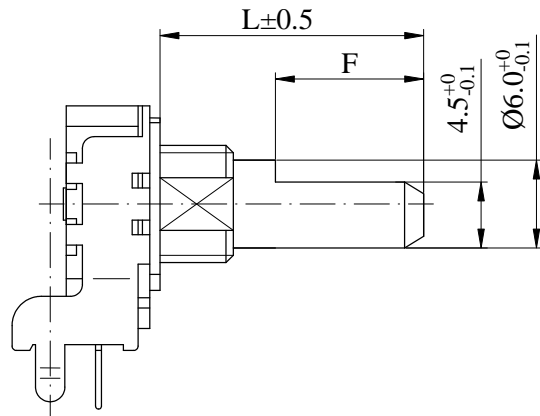

Vertical

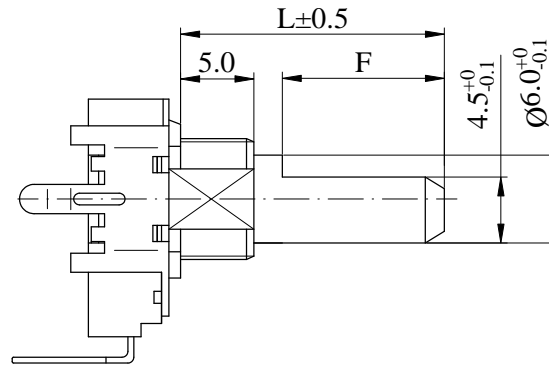

KC Type

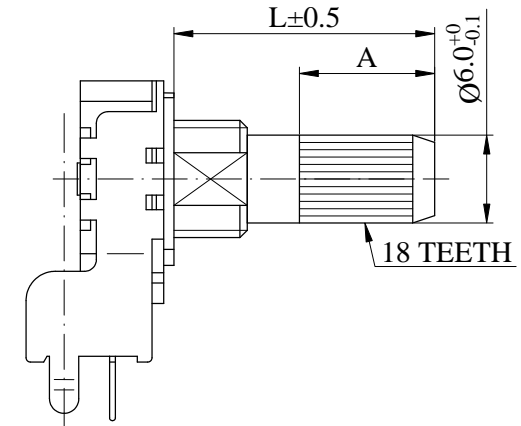

F Type

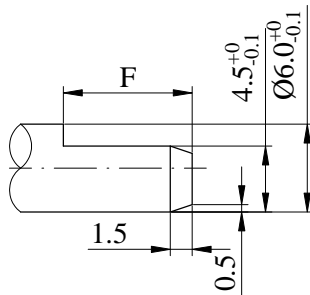

KC Type

L=	12.5	15	17.5	20	25
A=	7	7	12	12	12

F Type

L=	12.5	15	17.5	20	22.5	25	27.5	30
F=	7	7	12	12	12	12	12	12