



ISO 9001 國際品質認證
ISO 9001 CERTIFICATE

松暉電機工業股份有限公司
SONG HUEI ELECTRIC CO., LTD.
佛山市松暉電機科技有限公司
FOSHAN SONG HUEI ELECTRIC CO., LTD.

1.一般事項 General			
項目 Item	測試條件 Test Conditions	規格 Performance	
1	額定值 Rating	DC 12 V 50 mA	/
2.电气性能 Electrical Characteristics			
項目 Item	測試條件 Test Conditions	規格 Performance	
2.1	接觸電阻 Contact resistance	在以 DC 5 V 10 mA 的直流電源或不低於 1 KHz 的交流電源的電路中，以一個等於 2 倍按力的靜負荷施加於手柄中心。 Applying a static load of 2 times operating force to the center of the stem, measurements shall be made with DC 5 V 10 mA or more than 1 KHz AC circuit.	$\leq 100 \text{ m}\Omega$
2.2	絕緣電阻 Insulation resistance	施加 DC 100 V / 1 min 的條件下，測量端子之間及端子與蓋板的絕緣電阻。 Measurement shall be made following applying DC 100 V / 1 min between terminal and cover and between terminals, for one minute.	$\geq 100 \text{ M}\Omega$
2.3	介質耐壓 Dielectric voltage proof	在端子之間施加 AC 250 V (50 HZ 或 60 HZ) / 1 min。 AC 250 V (50 HZ or 60 HZ) shall be applied across terminals for one minute.	無擊穿、無飛弧 There should be no breakdown and flashover.
2.4	觸點抖動 Bounce	按照正常使用時的力度輕按手柄中心每秒 3 ~ 4 次，在導通和斷開過程中測試開關抖動。 Lightly striking the center of the stem at a rate of 3 to 4 times per second, and bounce shall be tested at "ON" and "OFF".	ON - 3 msec. max OFF - 8 msec. max
	<p>图一 (Figure 1)</p>		
3.機械性能 Mechanical Characteristics			
項目 Item	測試條件 Test Conditions	規格 Performance	
3.1	按力 Operating force	開關垂直於操作方向放置，在開關驅動件頂端中心逐漸施力，測量開關導通所需的最大力。 Placing the switch at the direction of switch operation is vertical and then gradually increasing the load applied to the center of the stem, the maximum load required for the switch to come to a stop shall be measured.	Refer to table 2
3.2	最大行程 Full travel	開關垂直於操作方向放置，以一個等於 2 倍按力的靜負荷施加在開關驅動件頂端中心，測量頂端移動的距離。 Placing the switch at the direction of switch operation is vertical and then applying static load of 2 times operating force to the center of the stem; the travel distance for the switch to come to a stop shall be measured.	$0.25 \pm 0.1 \text{ mm}$
3.3	回彈力 Return force	開關垂直於操作方向放置，在開關驅動件頂端中心下降至全行程後，測量頂端向自由位置轉換的力度。 The sample switch is installed at the direction of switch operation is vertical and upon depressing the stem in its center to the whole travel distance, the force of the stem to return to its free position shall be measured.	20 gf min
3.4	停止強度 Stop strength	開關垂直於操作方向放置，從操作方向向驅動件施加 30 N 的靜負荷持續 1 min。 Placing the switch at the direction of switch operation is vertical, and then a static load of 30 N shall be applied in the direction of stem operation for 1 min.	無機械和電氣損壞 There shall be no sign of damage mechanically and electrically.



ISO 9001 國際品質認證
ISO 9001 CERTIFICATE

松暉電機工業股份有限公司
SONG HUEI ELECTRIC CO., LTD.
佛山市松暉電機科技有限公司
FOSHAN SONG HUEI ELECTRIC CO., LTD.

3.5	手柄拔出強度 Stem strength	開關垂直於操作方向放置，反方向實施最大操作力，並測量手柄的行程範圍。 Placing the switch at the direction of switch operation is vertical, and then the maximum force to withstand a pull applied opposite to the direction of stem operation shall be measured.	20 N.min.
3.6	可焊性 Solderability	在以下設定條件下進行測量： Measurements shall be made following the below test set: (1) 焊接溫度：245 ± 5 °C Solder temperature: 245 ± 5 °C (2) 浸入時間：3 s ± 0.5 s Immersion time: 3 s ± 0.5 s 對於其它步驟參考《GB 5095.6 - 86》試驗 12 a The other steps please refer to 《GB 5095.6 - 86》 test 12 a	除邊緣外塗層應均勻覆蓋 90 % 以上。 Except for the edge , the coating should cover more than 90 %.

4.極限電氣性能 Environmental Specification

項目 Item	測試條件 Test Conditions	規格 Performance
4.1	低溫試驗 Resistance to low temperature	接觸電阻：≤ 200 mΩ Contact resistance: ≤ 200 mΩ 項目：2、3.1、3.2、3.3 Item: 2、3.1、3.2、3.3
4.2	高溫試驗 Heat resistance	接觸電阻：≤ 200 mΩ Contact resistance: ≤ 200 mΩ 項目：2、3.1、3.2、3.3 Item: 2、3.1、3.2、3.3
4.3	溫度週期性試驗 Change of temperature	接觸電阻：≤ 200 mΩ Contact resistance: ≤ 200 mΩ 項目：2、3.1、3.2、3.3 Item: 2、3.1、3.2、3.3
4.4	濕溫測試 Moisture resistance	接觸電阻：≤ 200 mΩ Contact resistance: ≤ 200 mΩ 項目：2、3.1、3.2、3.3 Item: 2、3.1、3.2、3.3
4.5	鹽霧試驗 Salt mist	金屬件上沒有腐蝕斑點。 No remarkable corrosion shall be recognized in metal part.

樣品應按照以下實驗條件進行測試，實驗後樣品應放在常溫及標準濕度的環境中 1 小時後做性能測試：
Following the test set below, then the sample shall be left in normal temperature and humidity conditions for 1 hour before measurements are made:
(1) 溫度：-30 ± 2 °C Temperature: -30 ± 2 °C
(2) 時間：96 h Time: 96 h

樣品應按照以下實驗條件進行測試，實驗後樣品應放在常溫及標準濕度的環境中 1 小時後做性能測試：
Following the test set below, then the sample shall be left in normal temperature and humidity conditions for 1 hour before measurements are made:
(1) 溫度：80 ± 2 °C Temperature: 80 ± 2 °C
(2) 時間：96 h Time: 96 h

根據下面的測試要求進行 5 次循環的溫度週期性測試，實驗後樣品應放在常溫及標準濕度的環境中 1 小時後做性能測試。測試期間樣品應保持乾燥。
After 5 cycles of following conditions, the sample shall be placed under normal temperature and humidity conditions for 1 hour, and measurements shall be made. During the test, water drops shall be removed .

1 cycle	Temperature	Time (hour)
	-10 ± 2 °C	2
	-10 ~ 65 °C	1
	65 ± 2 °C	2
	65 ~ -10 °C	1

表 1 (Table 1)

樣品應按照以下實驗條件進行測試，實驗後樣品應放在常溫及標準濕度的環境中 1 小時後做性能測試：
Following the test set below, then the sample shall be left in normal temperature and humidity conditions for 1 hour before measurements are made:
(1) 溫度：60 ± 2 °C Temperature: 60 ± 2 °C
(2) 相對濕度：90 % ~ 95 % Relative humidity: 90 % to 95 %
(3) 時間：96 h Time: 96 h

在以下設定條件下進行測量：
The switch shall be checked after following test:
(1) 溫度：35 ± 2 °C Temperature: 35 ± 2 °C
(2) 鹽溶液濃度：5 ± 1 % (品質百分比) Salt solution: 5 ± 1 % (solids by mass)
(3) 時間：8 h ± 1 h Time: 8 h ± 1 h
實驗後的鹽沉積物用水沖掉
After test, salt deposit shall be removed by running water.



ISO 9001 國際品質認證
ISO 9001 CERTIFICATE

松暉電機工業股份有限公司
SONG HUEI ELECTRIC CO., LTD.
佛山市松暉電機科技有限公司
FOSHAN SONG HUEI ELECTRIC CO., LTD.

5. 極限機械性能 Endurance Specification		
項目 Item	測試條件 Test Conditions	規格 Performance
5.1 工作壽命 Operation life	根據下面的測試要求進行測試： Measurement shall be made following the test set below: (1) DC 12 V 50 mA 帶負載。 (1) DC 12 V 50 mA resistive load. (2) 按動速率：2 ~ 3 次 / 秒。 (2) Rate of operation: 2 ~ 3 time / s. (3) 按力：按力的 1.5 ~ 2 倍。 (3) Operating force: 1.5 ~ 2 times of operating force. (4) 壽命Life: <input type="checkbox"/> 100 gf: 80000 cycles <input type="checkbox"/> 160 gf: 60000 cycles <input type="checkbox"/> 250 gf: 50000 cycles	接觸電阻：≤ 200 mΩ Contact resistance: ≤ 200 mΩ 觸點彈力：≤ 10 ms Contact bounce: ≤ 10 ms 按力：初值的 ± 30 % Operating force: initial value ± 30 % 項目：2、3.1、3.2、3.3 Item: 2、3.1、3.2、3.3
5.2 振動 Vibration	根據以下給定條件進行測試： Measurement shall be made following the test below: (1) 振動頻率範圍：10 ~ 55 ~ 10 Hz Vibration frequency range: 10 to 55 to 10 Hz (2) 振幅(峰 ~ 峰)：1.5 mm Amplitude: 1.5 mm (3) 振動方向：包括手柄行程方向在內的三個互垂直的方向 Direction of vibration : three mutually perpendicular direction including the direction of stem travel. (4) 測試時間：每次 2 hours Duration: each time 2 hours.	項目：2、3.1、3.2、3.3 Item: 2、3.1、3.2、3.3
6. 焊接條件 Soldering Conditions		
項目 Item	測試條件 Test Conditions	規格 Performance
6.1 手工焊接 Hand soldering	請按以下條件下進行焊接： Please practice according to below conditions: (1) 焊錫溫度：≤ 350 °C Soldering temperature: 350 °C max. (2) 連續焊接時間：≤ 3 s max Continuous soldering time: ≤ 3 s max.	/
	項目 Items	條件 condition
6.2 自動浸焊 Conditions for auto- dip	助焊劑附著量 Flux built-up	不附著於零件貼裝面的程度 Mounting surface should not be coated with flux
	預熱溫度 Preheating temperature	印刷電路板焊接面的周圍溫度 100 °C max Ambient temperature of the soldered surface of PC board 100 °C max
	預熱溫度時間 Preheating time	60 s max
	焊接溫度 Soldering temperature	260 °C max
	接焊浸漬時間 Continuous dipping time	5 s max
	焊接次數 Number of soldering	2 次以下 2 times max

Operating Force		
<input type="checkbox"/> 100 gf ± 30 gf	<input type="checkbox"/> 160 gf ± 50 gf	<input type="checkbox"/> 250 gf ± 100 gf
表 2 (Table 2)		

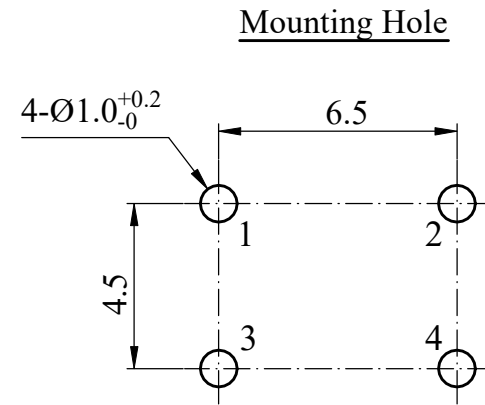
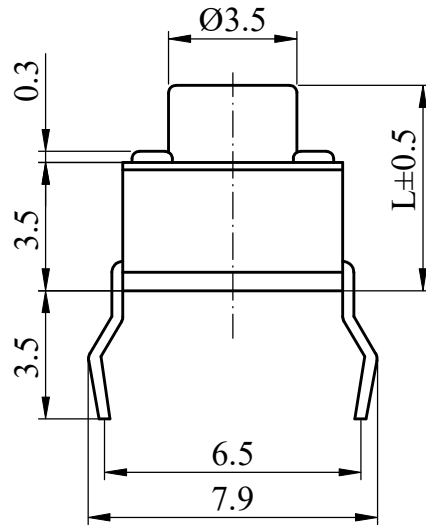
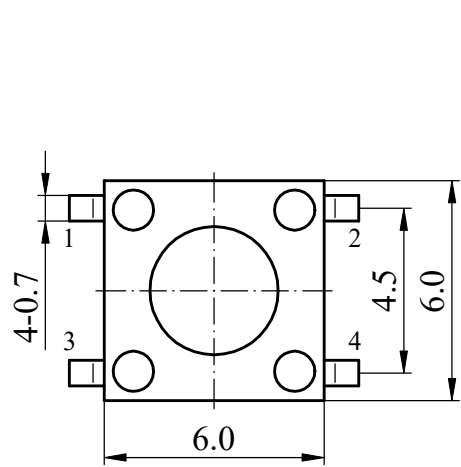

CIRCUIT

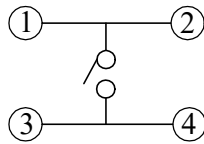

Model No	L=	choose	Model No	L=	choose
TS6601H	4.3		TS6601HI	6.0	
TS6601HA	5		TS6601HJ	9.0	
TS6601HB	7		TS6601HK	11.0	
TS6601HC	8		TS6601HL	11.5	
TS6601HD	9.5		TS6601HM	12	
TS6601HE	7.3		TS6601HN	13	
TS6601HF	12.5		TS6601HR	15	
TS6601HG	13.5		TS6601HX	17	
TS6601HH	6.5		TS6601HZ	21	

Non notation tolerance	
< 10	±0.3
10 ~ 100	±0.5
> 100	±0.8



SONG HUEI ELECTRIC CO., LTD.
FOSHAN SONG HUEI ELECTRIC CO., LTD.

MODEL: TS6601H_/0516



增加TS6601HZ,L=21 何鸿根 2022.06.24

ISSUE SUBJECT NAME DATE

RECORD

Approval



Checked



Projected



UNIT

mm

SCALE

3:1

VERSION

1.1

DATE

2022.04.18

DRAWING NO.

TS-056

